

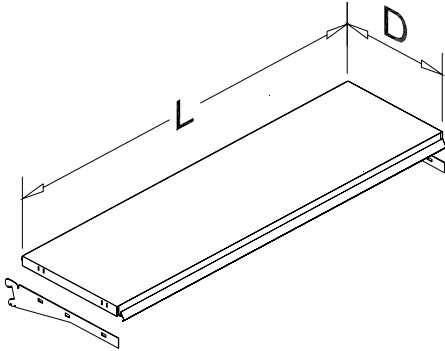

# SHELVES & ACCESSORIES

SHOPCO U.S.A. INC.



## Straight Solid Shelf

SH1-FSXXXX-XXXXXXX-0

Features:

- Includes "2 hook" brackets with three angle adjustments
- Available 2, 3 & 4 ft. lengths
- Standard depths include 10, 12, 14 & 16 in.
- Other sizes available

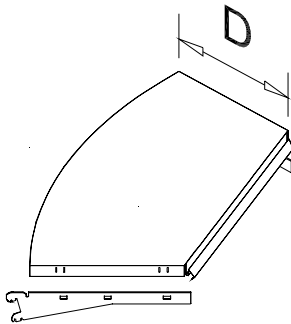

## Inside Curved Solid Shelf

SH1-FS1/8I-XXXXXXX-0

Features:

- Includes "2 hook" brackets
- Standard depths include 12 & 16 in.
- Attaches to inside curved shelving section

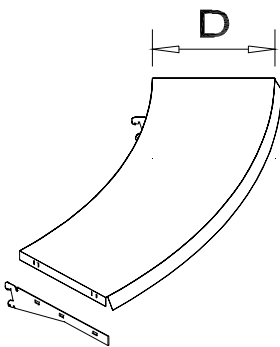

## Outside Curved Solid Shelf

SH1-FS1/8O-XXXXXXX-0

Features:

- Includes "2 hook" brackets
- Standard depths include 12 & 16 in.
- Attaches to outside curved shelving section

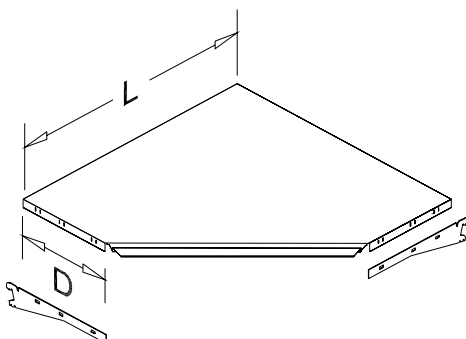

## Inside 90 Degree Corner Solid Shelf

SH1-FCXXXX-28XXXXX-0

Features:

- Includes "2 hook" brackets
- Standard depths include 12 & 16 in.
- Used for inside 90 degree corner applications (wall units)

# SHELVES & ACCESSORIES

SHOPCO U.S.A. INC.

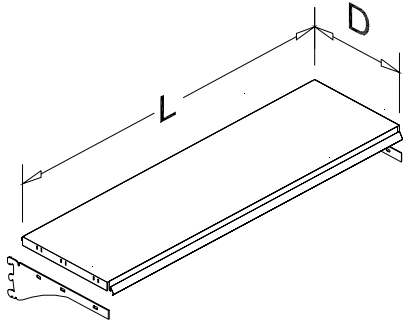

## Heavy Duty Solid Shelf

SH1-FSHDXX-XXXXXXX-0

Features:

- Includes reinforcement bar(s) as shown below
- Includes "3 hook" brackets with two angle adjustments
- Available 2, 3 & 4 ft. lengths
- Standard depths include 12 & 16 in.
- Other sizes available (\*lead time)

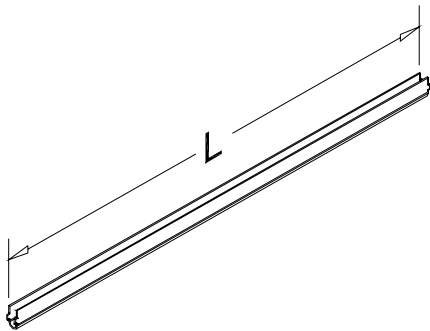

## Reinforcement Bar

1304-XXXXXXX-XX

Features:

- Attaches to solid shelf to accommodate heavy duty shelving needs
- 12 & 14 in. deep solid shelves require one reinforcement bar
- 16 - 24 in. deep solid shelves require two reinforcement bars

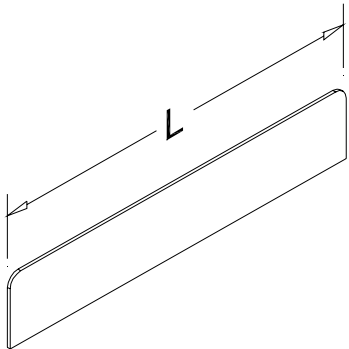

## Front Fence

(For Shelves with Price Ticket Rails)

5941-XXXXXXX-XX

Features:

- Clear acrylic
- For use with solid shelves only
- See below item if solid shelf does not require price ticket rails
- Available 2, 3 & 4 ft. lengths
- Available for inside curved shelves

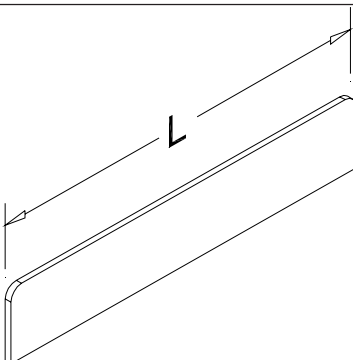

## Front Fence

(For Shelves without Price Ticket Rails)

5940-XXXXXXX-XX

Features:

- Clear acrylic
- For use with solid shelves only
- See above item if solid shelf requires price ticket rails
- Available 2, 3 & 4 ft. lengths
- Available for inside curved corner shelves



# SHELVES & ACCESSORIES

SHOPCO U.S.A. INC.

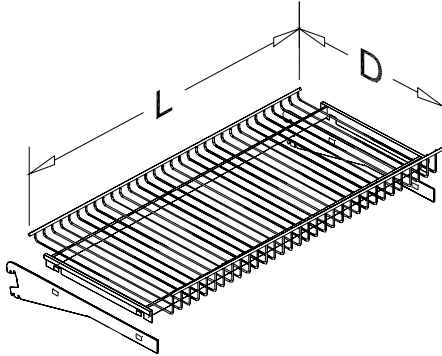

## Straight Wire Shelf

SH1-WSXXNG-XXXXXXX-0

### Features:

- Includes "2 hook" brackets with three angle adjustments
- Available 2, 3 & 4 ft. lengths
- Standard depths include 6, 8, 10, 12, 14 & 16 in.
- Standard 2 in. lip
- Reversible for 1/2 in. lip
- 12 & 16 in. deep also available with a 4 in. lip
- Special 1 ft. lengths available with 8, 10 & 12 in. depths

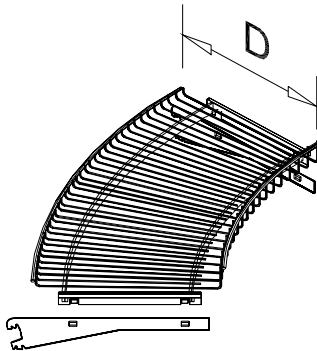

## Inside Curved Wire Shelf

SH1-WSR90I-XXXXXXX-0

### Features:

- Attaches to inside curved shelving section
- Includes "2 hook" brackets
- Standard depths include 8, 10, 12 & 16 in.
- Standard 2 in. lip

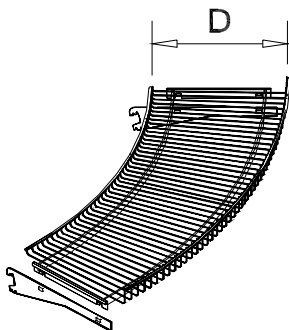

## Outside Curved Wire Shelf

SH1-WSR90O-XXXXXXX-0

### Features:

- Attaches to outside curved shelving section
- Includes "2 hook" brackets
- Standard depths include 8, 10, 12 & 16 in.
- Standard 2 in. lip

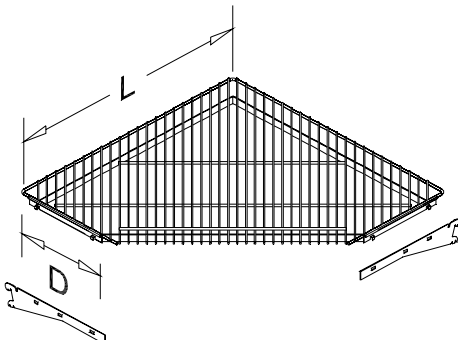

## Inside 90 Degree Corner Wire Shelf

SH1-WSCNXX-2812002-0

### Features:

- Includes "2 hook" brackets
- Standard depth: 12 in.
- Used for inside 90 degree corner applications (wall units)

# SHELVES & ACCESSORIES

SHOPCO U.S.A. INC.

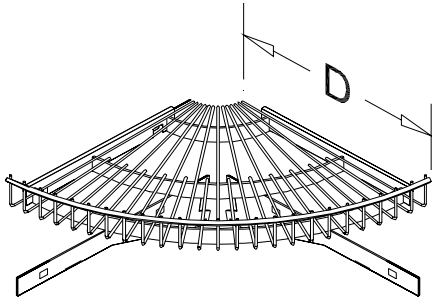
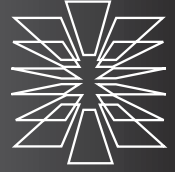

## 1/4 Circle Corner Curved Wire Shelf

SH1-WS4XXX-XXXXXXXX-0

Features:

- For use on sales counter and 90 degree triangle end cap applications
- Includes "2 hook" brackets
- Standard depths include 8, 10, 12 & 16 in.
- Standard 2 in. lip

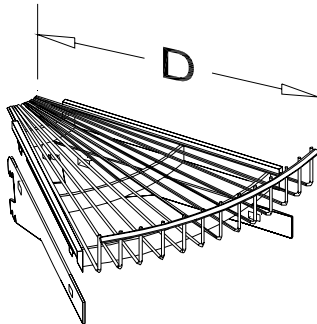

## 1/8 Circle Corner Curved Wire Shelf

SH1-WS8XXX-XXXXXXXX-0

Features:

- Used for sales counter applications
- Includes "2 hook" brackets
- Standard depths include 8 & 12 in.
- Standard 2 in. lip

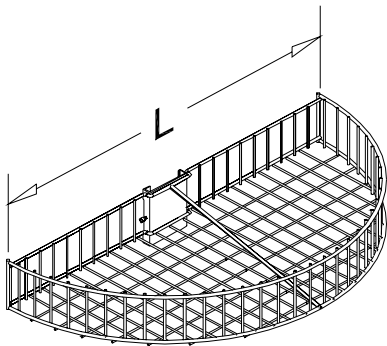

## 1/2 Circle Basket Wire Shelf (center mount)

1770-XXXXXXXX-XX

Features:

- Mounts to large 2D upright
- Used for wrap units or in place of an end cap
- Standard lengths 28 & 36 in.
- Standard 4 in. lip

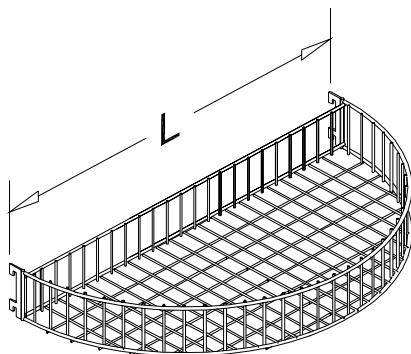

## 1/2 Circle Basket Wire Shelf (side mount)

1780-XXXXXXXX-XX

Features:

- For use on end cap units
- Standard length 36 in.
- Standard 4 in. lip



# SHELVES & ACCESSORIES

SHOPCO U.S.A. INC.

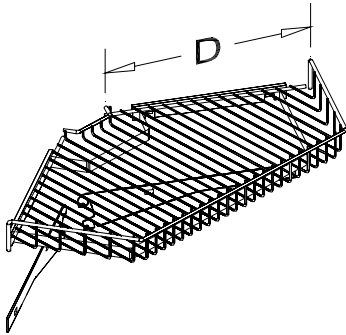

## 120 Degree Wire Shelf

SH1-WS120X-XXXXXXX-0

### Features:

- For use on 60 degree triangle gondola unit
- Includes "2 hook" brackets
- Standard depths include 8 & 12 in.
- Standard 2 in. lip

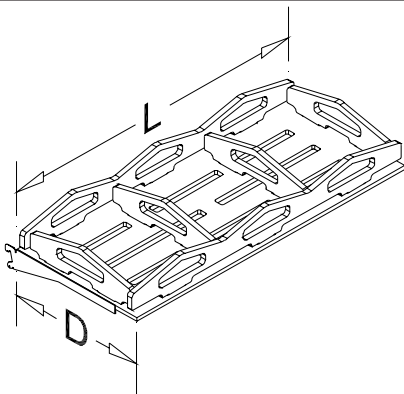

## Wood Wine Shelf

SH1-WWSXXX-3616004-0

### Features:

- Attaches to wall units, gondola units and end cap units
- 3 ft. L X 16 in. D
- Includes front fence and dividers as shown

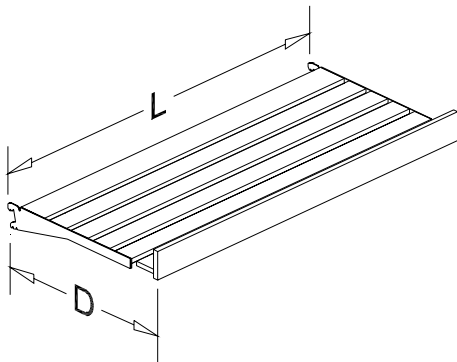

## Wood Bread Shelf

SH1-WBSXXX-3616003-0

### Features:

- Attaches to wall units, gondola units and end cap units
- 3 ft. L X 16 in. D
- 3 in. lip

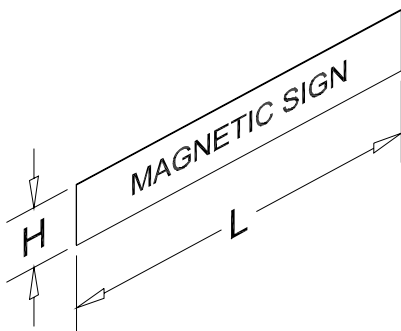

## Magnetic Sign

3940-18XX004-01

### Features:

- Attaches to all metal shelving units
- Standard size: 18 in. L X 4 in. H
- Any text and color available
- Call for more information

# SHELVES & ACCESSORIES

SHOPCO U.S.A. INC.

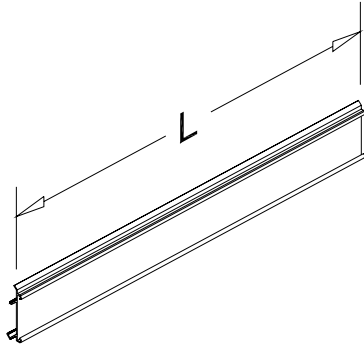

## Price Ticket Rail

For straight solid shelf & curved inside solid shelf  
4000, 4003 or 4006-XXXXXXX-XX

### Features:

- Available for 2, 3 & 4 ft. length straight shelves
- Available for 12 & 16 in. deep 1/8 circle curved inside shelves
- Available colors include: clear, black, white, beige, red, yellow, blue, dark blue & green

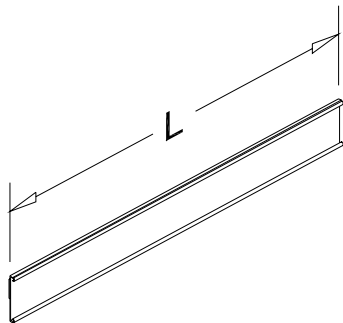

## Price Ticket Rail

For curved outside solid shelf  
4007-XXXXXXX-XX

### Features:

- Available for 12 & 16 in. deep shelves
- Attaches with double sided adhesive tape
- Available colors include: clear, black, white, beige, red, yellow, blue, dark blue & green

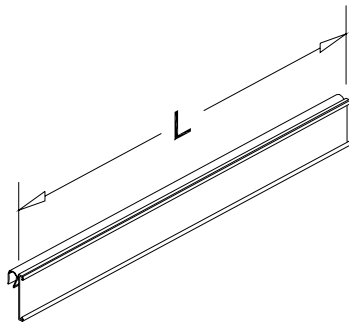

## Price Ticket Rail

For straight wire shelf  
4009, 4010 or 4013-XXXXXXX-XX

### Features:

- Available for 2, 3 & 4 ft. length straight shelves
- Available colors include: clear, black, white, beige, red, yellow, blue, dark blue & green

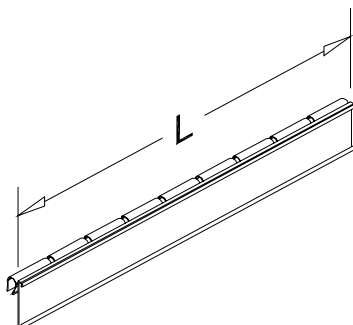

## Price Ticket Rail

For all curved wire shelves  
4017, 4019, 4020, 4021, 4022 or 4023-XXXXXXX-XX

### Features:

- Available for 12 & 16 in. deep inside and outside curved wire shelves & 1/8 circle corner curved wire shelves
- Available for 8, 10, 12 & 16 in. deep 1/4 circle corner curved wire shelves
- Available for 8 & 12 in. deep 120 degree wire shelves
- Available colors include: clear, black, white, beige, red, yellow, blue, dark blue & green



# SHELVES & ACCESSORIES

SHOPCO U.S.A. INC.

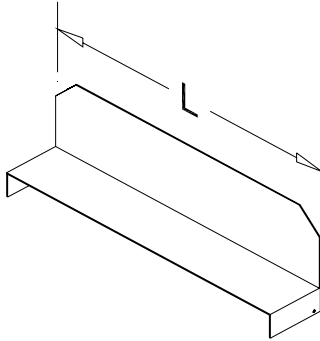

## Solid Shelf Divider

1305-XXXXXXX-XX

Features:

- All Metal
- Available in many sizes; call for more information

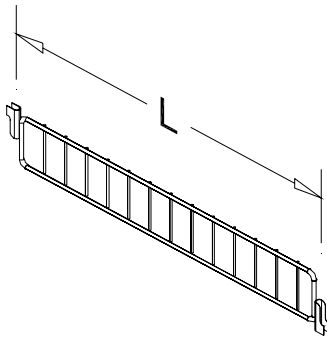

## Wire Shelf Divider

1710-XXXXXXX-XX

Features:

- Available for 6, 8, 10, 12, 14 & 16 in. deep wire shelves
- Standard height 2 in.
- Also available in 4 in. height for 12 & 16 in. deep wire shelves

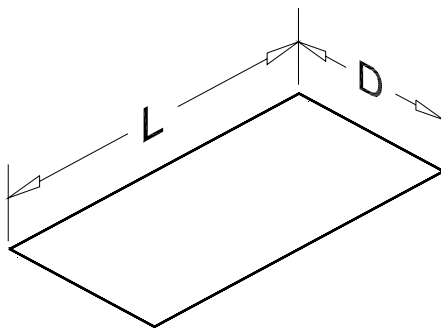

## Wire Shelf Liner

4300-XXXXXXX-XX

Features:

- Clear plastic liner to place on shelf
- Available lengths 2, 3 & 4 ft.
- Available depths 8, 10, 12, 14 & 16 in.

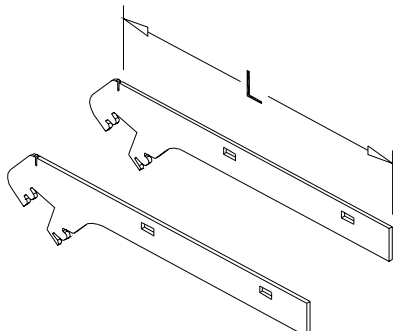

## Steep Angle Brackets

1730-XXXXXXX-XX

Features:

- Replace standard brackets to allow the same shelf to be angled at 50, 65 or 75 degrees
- For use with solid or wire shelves
- Available for 8, 10, 12 & 16 in. deep shelves
- Available colors are white and light gray

# SHELVES & ACCESSORIES

SHOPCO U.S.A. INC.

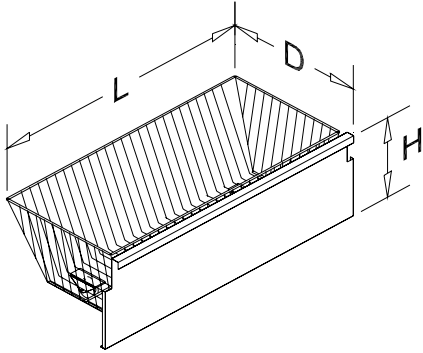
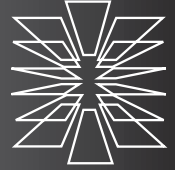

## Base Drawer Basket

SH1-BDBXXX-XXXXXXX-0

### Features:

- Fits under wall unit, gondola unit and end cap unit base shelves (straight sections only)
- Available lengths 2, 3 & 4 ft.
- Standard stock base panel colors are dark beige, black & dark gray; wire basket is chrome
- Custom colors available
- For use with standard foot only

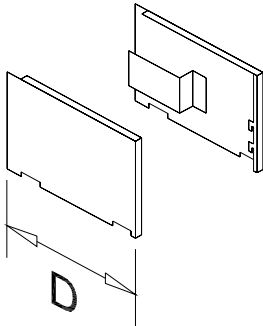

## Side Base Panels

115L-XXXXXXX-XX and 115R-XXXXXXX-XX

### Features:

- For use on gondola starter units without end caps
- Height 7 in.
- Available for 12 & 16 in. deep units
- Call for other sizes

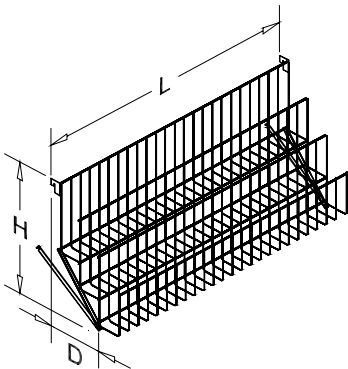

## 3 Tier Magazine Rack

1865-XXXXXXX-XX

### Features:

- Attaches to wall units, gondola units & sales counters
- Available in straight and outside curved configurations
- See page 52 for more details

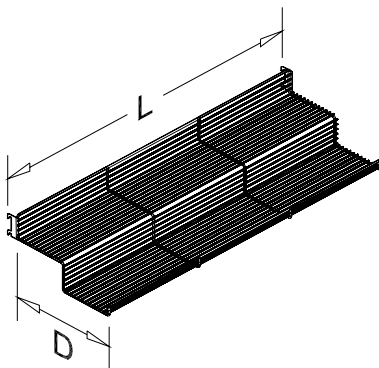

## Pastry Rack

1840-XXXXXXX-XX

### Features:

- Attaches to wall units, gondola units & end cap units
- 2 levels
- Available lengths 2 & 3 ft.
- Standard stock colors are white, beige & light gray
- Custom colors available



# SHELVES & ACCESSORIES

SHOPCO U.S.A. INC.

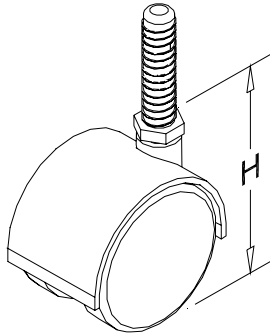

## Caster

0522-XXXX002-08

Features:

- Load capacity 75 lbs.
- Height 2 in.
- Best used with T-Foot or L-Foot configurations

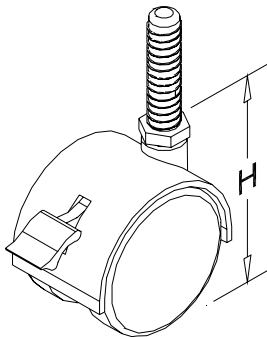

## Caster with Brake

0521-XXXX002-08

Features:

- Load capacity 75 lbs.
- Height 2 in.
- Best used with T-Foot or L-Foot configurations

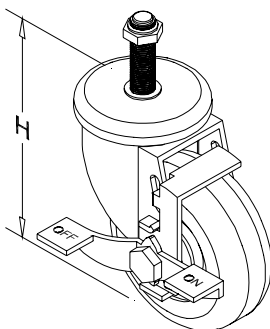

## Heavy Duty Caster

4830-XXXX003-08

Features:

- Load capacity 150 lbs.
- Height 3 in.

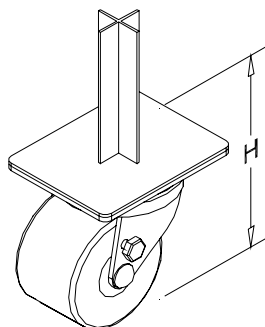

## Heavy Duty Triangle Caster

4831-XXXX004-08

Features:

- Used for 60 degree triangle gondola unit
- 60 degree triangle gondola unit requires 3 casters
- Load capacity 200 lbs.
- Height 4 in.

# SHELVES & ACCESSORIES

SHOPCO U.S.A. INC.

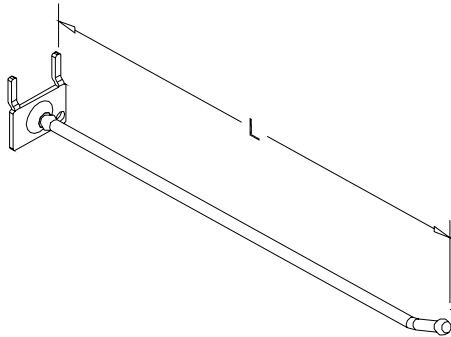
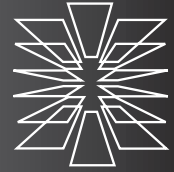

## Standard Peg Hook

3175-XXXXXXXX-XX

Features:

- Available lengths 6 & 8 in.
- Standard stock colors are white, beige & galvanized
- 12 in. also available in white

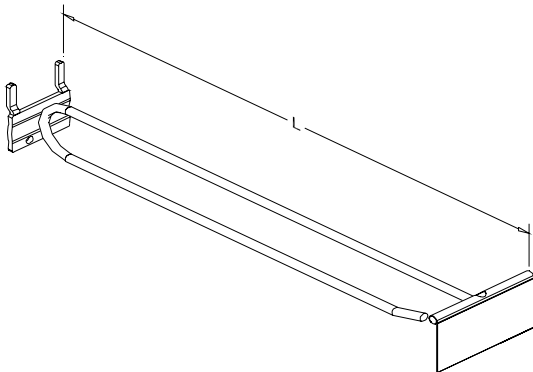

## Scanning Peg Hook

3204-XXXXXXXX-XX

Replaces 3145 hooks

Features:

- Available lengths 6 & 8 in.
- Standard stock colors include white, beige and gray
- 10 in. also available in gray
- Includes flip scan label holder

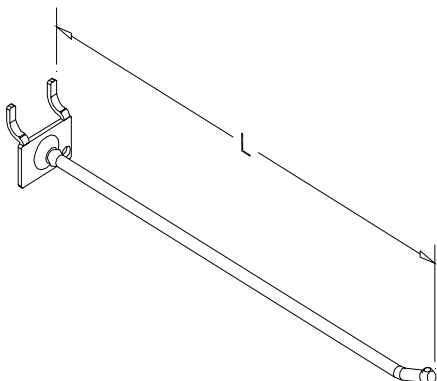

## Standard Slat and Mini-Slat Hook

3170-XXXXXXXX-XX

Features:

- Available lengths 6 & 8 in.
- Standard stock colors include white, beige and galvanized
- 4 in. also available in galvanized



# SHELVES & ACCESSORIES

SHOPCO U.S.A. INC.

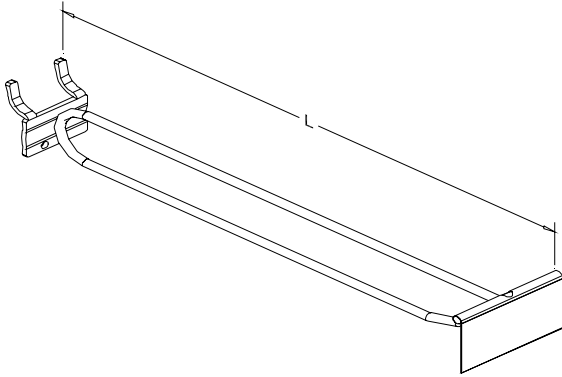

## Scanning Slat and Mini-Slat Hook

3208-XXXXXXX-XX

Replaces 3150 hooks

### Features:

- Available lengths 6 & 8 in.
- Standard stock color is galvanized
- 11 in. also available in white
- Includes flip scan label holder

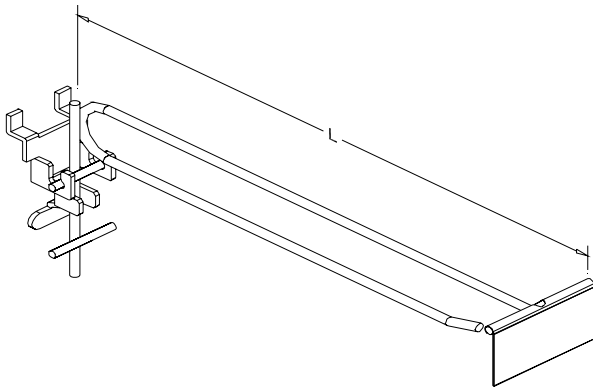

## Universal Adjustable Slat Scanning Hook

3212-XXXXXXX-XX

Replaces 3163 hooks

### Features:

- Used for slat and mini-slat panels
- Available lengths 6 & 8 in.
- Standard stock colors include white, beige and galvanized
- 8 in. also available in red
- Includes flip scan label holder and metal back plate

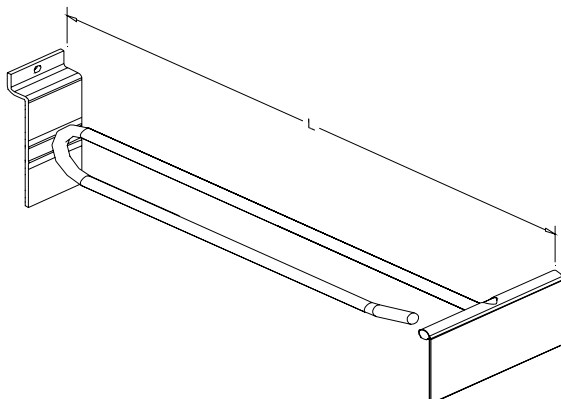

## Heavy Duty Mini-Slat Scanning Hook

3214-XXXXXXX-XX

Replaces 3165 hooks

### Features:

- Available lengths 4, 8 & 10 in.
- Standard stock color is galvanized
- Includes flip scan label holder

# SHELVES & ACCESSORIES

SHOPCO U.S.A. INC.

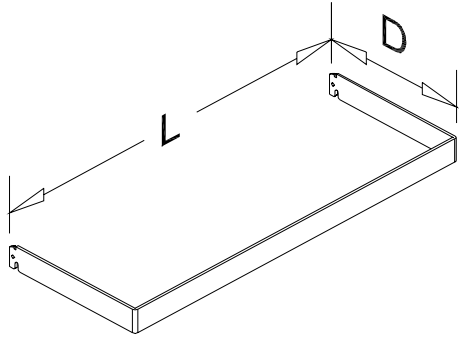
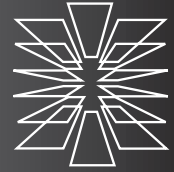

## Uni-Frame

3050-XXXXXXX-XX

Features:

- Attaches to wall units, gondola units & end cap units
- Available lengths 2, 3 & 4 ft.
- Available depths 1, 8 & 12 in.
- Standard stock color is white

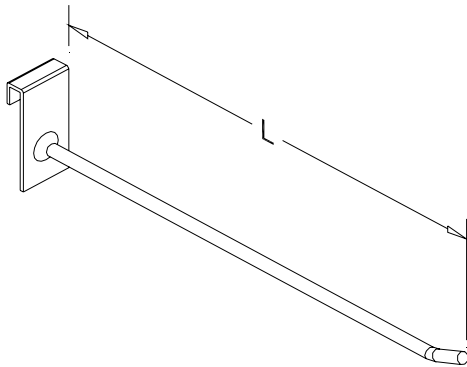

## Uni-Frame Hook

3060-XXXXXXX-XX

Features:

- Available lengths 4, 6 & 8 in.
- Standard stock color is chrome

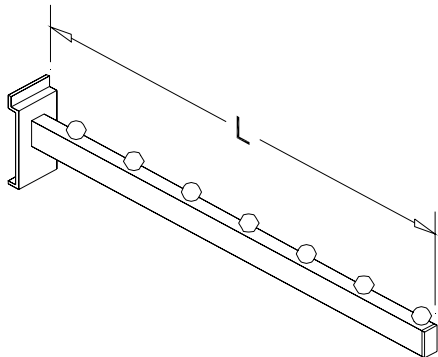

## Straight Hang Bar

3186-XXXXXXX-XX

Features:

- Available length 16 in.
- Standard stock color is chrome
- For use with mini-slat wall

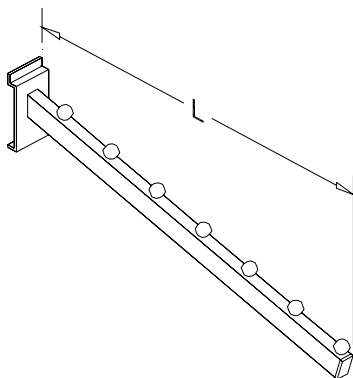

## Angled Hang Bar

3187-XXXXXXX-XX

Features:

- Available length 16 in.
- Standard stock color is chrome
- For use with mini-slat wall



# SHELVES & ACCESSORIES

SHOPCO U.S.A. INC.

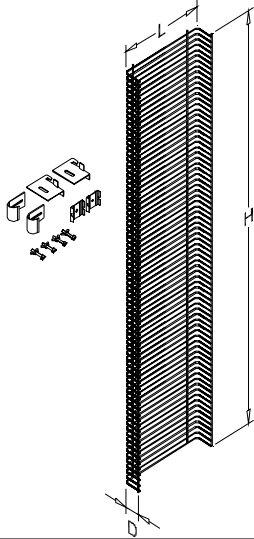

## Powerwing

SH1-PWHXXX-1404048-0

### Features:

- Attaches to end cap units
- 14.5 in. L X 4.5 in. D X 48 in. H
- Standard stock colors are white and gray
- Includes shelf and upright mounting kit

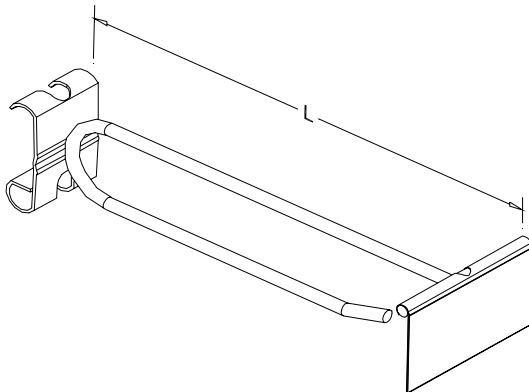

## Powerwing Hook

3200-XXXXXXXX-XX

Replaces 2960 hooks

### Features:

- Length 4 in.
- Standard stock colors are white and galvanized
- Includes flip scan label holder

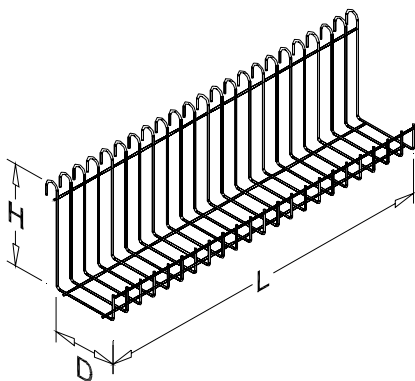

## Powerwing Shelf

2955-XXXXXXXX-XX

### Features:

- 13 in. L X 5 in. D X 5 in. H
- Standard stock colors are white and gray