

Madix Gondola System
by SHOPCO
Product Catalog

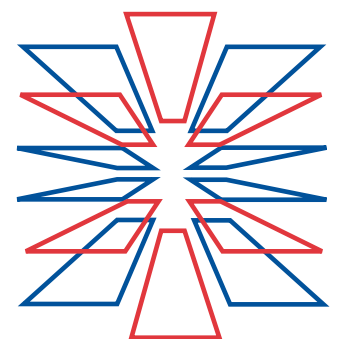

SHOPCO

The Merchandising System

Now! In Stock - Madix Gondolas From SHOPCO!

Finally, the industry standard gondola system with shelves that are interchangeable with most domestic gondola systems, is in stock and available for immediate delivery. SHOPCO carries a large inventory of gondolas and wall units in standard sizes in Sahara (beige) and black colors. Madix gondolas from SHOPCO offer the perfect shelving solution for C-stores, travel centers and many other retailers.

Give SHOPCO a call today!

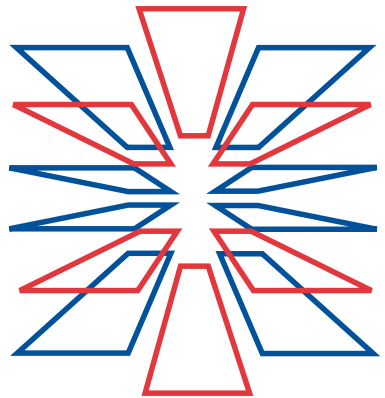

SHOPCO

The Merchandising System

SHOPCO's full service team can also assist you with:

- Store interior layout and design
- Award-winning sales counters designed to promote impulse sales
- Unique all-metal component cabinetry systems and accessories
- Custom counter tops including plastic laminate, solid surface, quartz and many others
- Turn-key service, including installation

SHOPCO has been a convenience store partner for over twenty five years, supplying thousands of c-stores throughout the country with our all metal European style shelving. Now we have teamed with **Madix** to offer an alternative to the higher priced systems. The **Madix** shelving is an industry standard that is compatible with many domestic shelving systems. This gives you the option of buying **Madix** shelves on a quick ship basis for your existing domestic manufactured gondolas. Or the option of ordering new Madix gondolas from SHOPCO and using existing shelves from your current inventory that wouldn't fit on our European style system

Madix fixtures are manufactured in a highly automated facility with the most modern technology to create store fixtures that are as cost effective as they are functional. Uprights are engineered of heavy gauge steel with a one inch slot pattern for adjustability and conformity to many other manufacturer's shelves as well as vendor racks. The five inch high foot is designed for ease of installation and structural integrity with levelers for use on all types of floors. The high density hardboard back panels fit flush with the front of the upright and are painted in various colors (in stock in Sahara and Black). Gondolas and wall units are stocked in 3-ft and 4-ft lengths, 54-in and 72-in heights, with base decks from 12-in and 16-in depths. Many other sizes and colors are available with standard fabrication lead times.

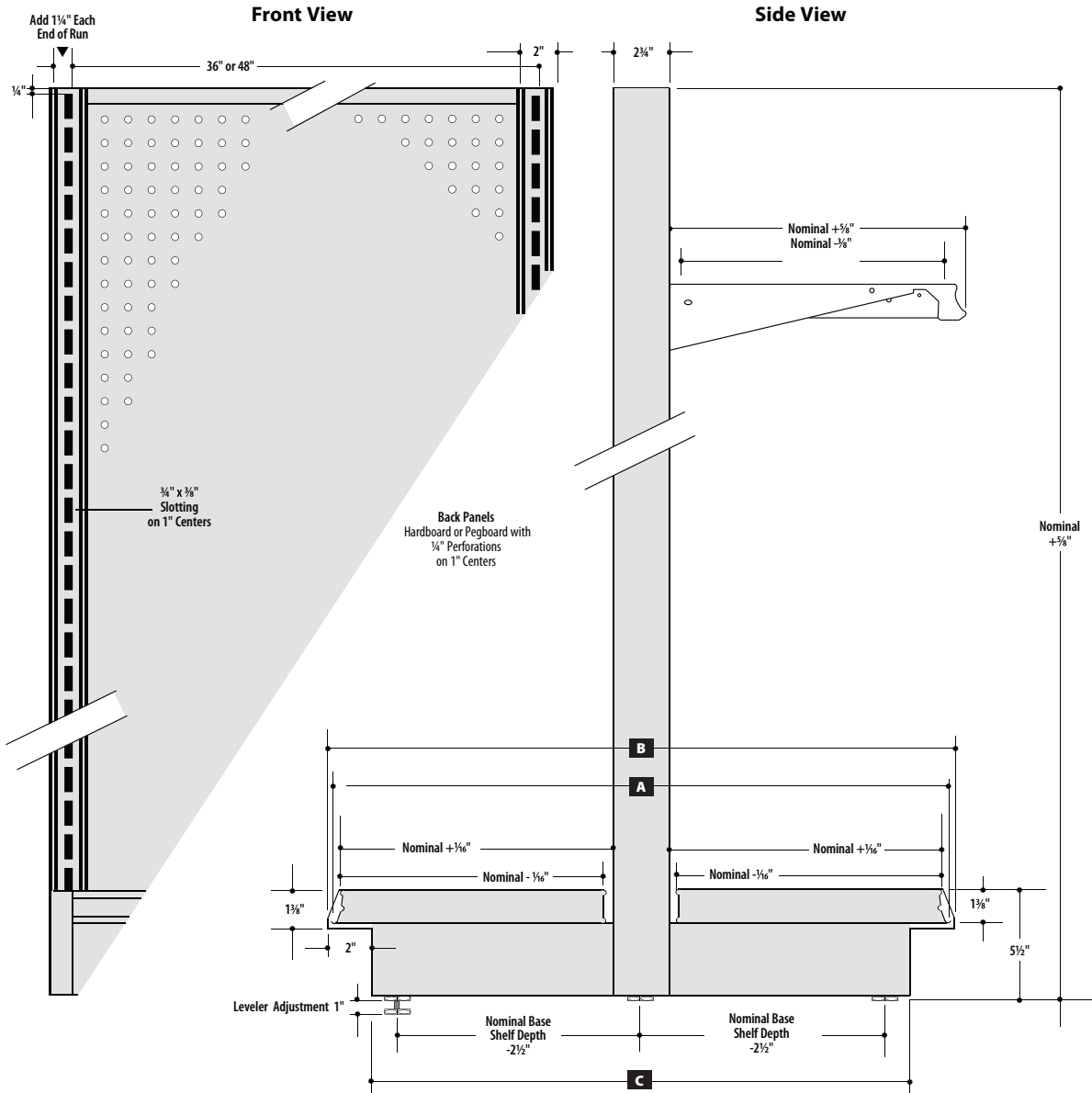

- Nominal Upright Heights
36" (914 mm) thru 96" (2438 mm)
in 6" (152 mm) increments
- Nominal Base Shelf Depths
12" (305 mm) thru 30" (762 mm)
in 2" (51 mm) increments
- Nominal Upper Shelf Depths
8" (203 mm) thru 30" (762 mm)
in 2" (51 mm) increments

NOTE! Dimensions are + or -1/8" and are subject to change without notice

Nominal Base Shelf Depth	plus 3"	plus	Nominal Base Shelf Depth	equals	Nominal Base Width
Bottom of Tag Mold to Bottom of Tag Mold	A		equals		minus 1/4"
Front of Base End Cover to Front of Base End Cover	B		equals		plus 7/8"
Front of Kickplate to Front of Kickplate	C		equals		minus 3 1/4"

Ordering Information

1. Starter units are designed to be freestanding. All shelving runs must contain a single starter unit. All other units in the run must be add-on units.

Add-on units are not freestanding. These units are used to continue a shelving run.

2. Base Unit configurations do not include accessories such as wire shelves, solid shelves, etc. unless otherwise stated.
3. Available colors are Sahara (beige) (#15) and black (#08)
4. The color designation above (either 08 or 15) should be inserted in place of the question marks in the 2nd and 3rd spaces of the Item No.

5. Configuration Number Nomenclature:

M08-GXPPXX-4816054-S

1st 3 digits: **M08=Madix+Color Designation**
(08 for Black or 15 for Sahara (beige))

Next 2 digits: **Type of Unit**
GX = Gondola
WX = Wall Unit
EX = End Cap
EF = End Frame
FS = Flat Shelf
WS = Wire Shelf

Next (2) digits: **Type of Back Panel (each side)**
P = Pegboard
H = Solid Hardwood
X = Not Applicable

Next (2) digits: **Qualifiers**
X = Standard Unit

Next 7 digits: **Size L x D x H**

Last digit: **Starter or Add-On**
S = Starter
A = Add-On

Gondola - Peg Board - Starter

Item #	L	D	H
M??-GXPPXX-3612054-S	3'	12"	54"
M??-GXPPXX-4812054-S	4'	12"	54"
M??-GXPPXX-3616054-S	3'	16"	54"
M??-GXPPXX-4816054-S	4'	16"	54"
M??-GXPPXX-3612072-S	3'	12"	72"
M??-GXPPXX-4812072-S	4'	12"	72"
M??-GXPPXX-3616072-S	3'	16"	72"
M??-GXPPXX-4816072-S	4'	16"	72"

*Side Base Panels - Ordered Separately
(Note: ?? = 08 for Black or 15 for Sahara (beige))

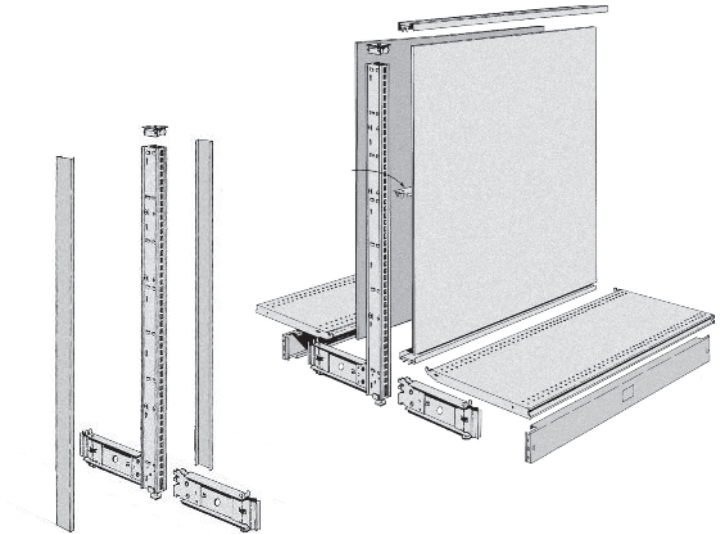

Gondola - Starter

**Gondola - Side Base Panels for Starter
(Set of One Left + One Right - Black)**

Item #	D	H
99-0620-XX12006-08	12"	6"
99-0620-XX16006-08	16"	6"

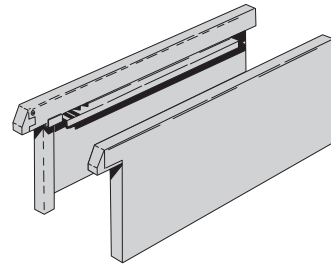

Gondola - Peg Board - Add-On

Item #	L	D	H
M??-GXPPXX-3612054-A	3'	12"	54"
M??-GXPPXX-4812054-A	4'	12"	54"
M??-GXPPXX-3616054-A	3'	16"	54"
M??-GXPPXX-4816054-A	4'	16"	54"
M??-GXPPXX-3612072-A	3'	12"	72"
M??-GXPPXX-4812072-A	4'	12"	72"
M??-GXPPXX-3616072-A	3'	16"	72"
M??-GXPPXX-4816072-A	4'	16"	72"

(Note: ?? = 08 for Black or 15 for Sahara (beige))

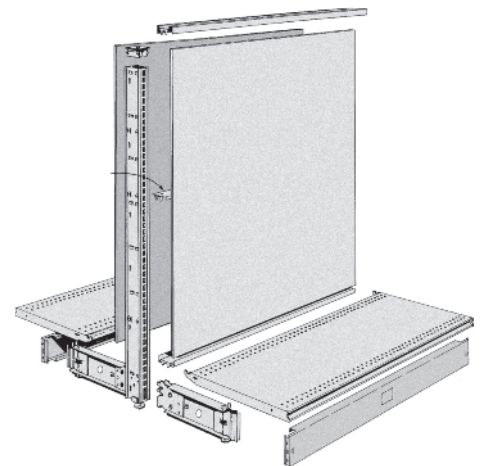

Gondola - Add-On

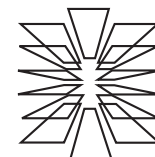

SHOPCO
The Merchandising System

Madix Gondola System (by SHOPCO)

End Cap - Peg Board - Starter

Item #	L	D	H
M??-EXPBXX-3612054-S	3'	12"	54"
M??-EXPBXX-3616054-S	3'	16"	54"
M??-EXPBXX-3612072-S	3'	12"	72"
M??-EXPBXX-3616072-S	3'	16"	72"

(Note: ?? = 08 for Black or 15 for Sahara (beige))

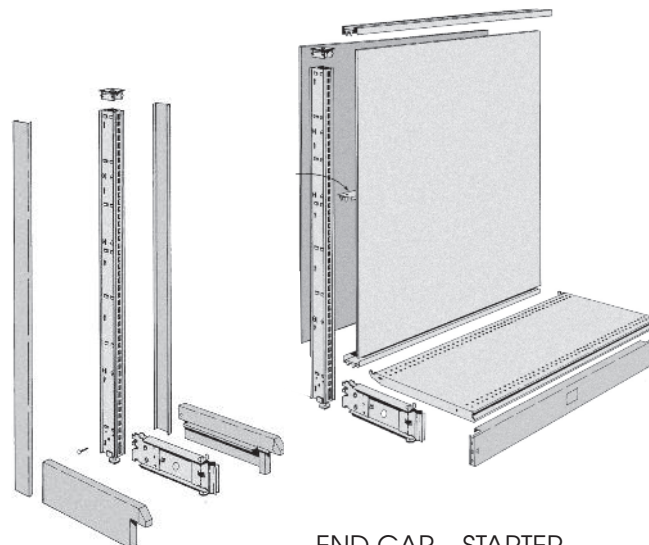

END CAP – STARTER

End Frame - Peg Board - Starter

Item #	L	D	H
M??-EFPXXX-36XX054-S	3'	n/a	54"
M??-EFPXXX-36XX072-S	3'	n/a	72"

(Note: ?? = 08 for Black or 15 for Sahara (beige))

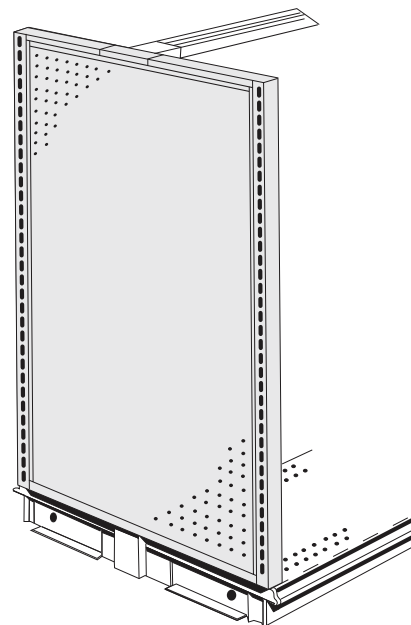

END FRAME

**Wall Unit - Peg Board - Starter
(peg board front - open back)**

Item #	L	D	H
M??-WXPXXX-3612054-S	3'	12"	54"
M??-WXPXXX-4812054-S	4'	12"	54"
M??-WXPXXX-3616054-S	3'	16"	54"
M??-WXPXXX-4816054-S	4'	16"	54"
M??-WXPXXX-3612072-S	3'	12"	72"
M??-WXPXXX-4812072-S	4'	12"	72"
M??-WXPXXX-3616072-S	3'	16"	72"
M??-WXPXXX-4816072-S	4'	16"	72"
M??-WXPXXX-3616084-S	3'	16"	84"
M??-WXPXXX-4816084-S	4'	16"	84"

(Note: ?? = 08 for Black or 15 for Sahara (beige))

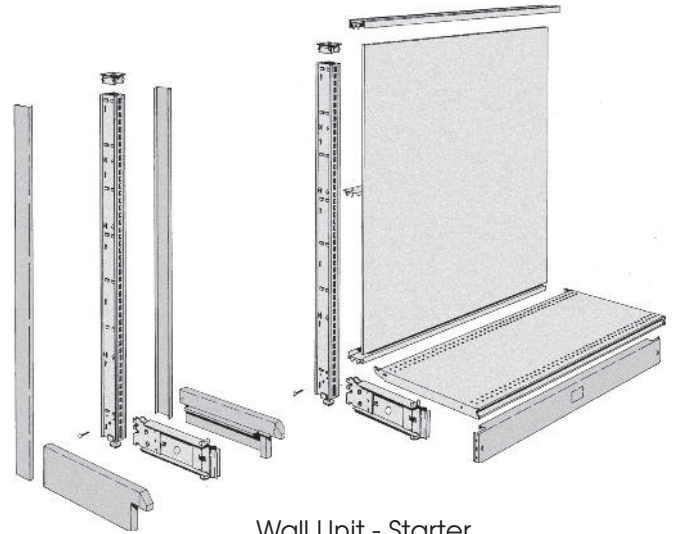

Wall Unit - Starter

**Wall Unit - Peg Board - Add-On
(peg board front - open back)**

Item #	L	D	H
M??-WXPXXX-3612054-A	3'	12"	54"
M??-WXPXXX-4812054-A	4'	12"	54"
M??-WXPXXX-3616054-A	3'	16"	54"
M??-WXPXXX-4816054-A	4'	16"	54"
M??-WXPXXX-3612072-A	3'	12"	72"
M??-WXPXXX-4812072-A	4'	12"	72"
M??-WXPXXX-3616072-A	3'	16"	72"
M??-WXPXXX-4816072-A	4'	16"	72"
M??-WXPXXX-3616084-A	3'	16"	84"
M??-WXPXXX-4816084-A	4'	16"	84"

(Note: ?? = 08 for Black or 15 for Sahara (beige))

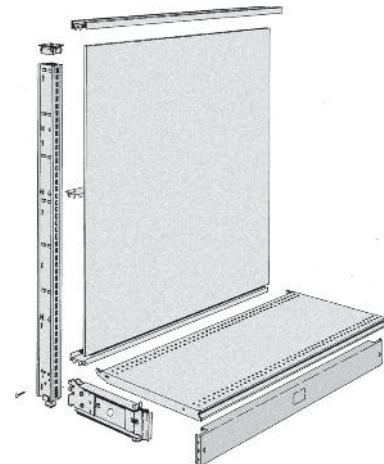

Wall Unit - Add-On

Madix Gondola System (by SHOPCO)

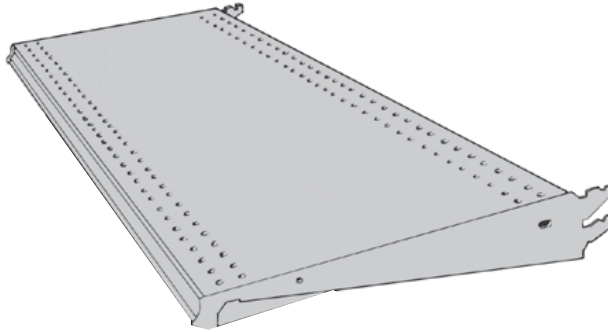

Solid Shelves with Brackets

Item #	L	D
99-1300-3608XXX-??	36"	8"
99-1300-3610XXX-??	36"	10"
99-1300-3612XXX-??	36"	12"
99-1300-3614XXX-??	36"	14"
99-1300-3616XXX-??	36"	16"
99-1300-3618XXX-??	36"	18"
99-1300-4808XXX-??	48"	8"
99-1300-4810XXX-??	48"	10"
99-1300-4812XXX-??	48"	12"
99-1300-4814XXX-??	48"	14"
99-1300-4816XXX-??	48"	16"
99-1300-4818XXX-??	48"	18"

(Note: ?? = 08 for Black or 15 for Sahara (beige))

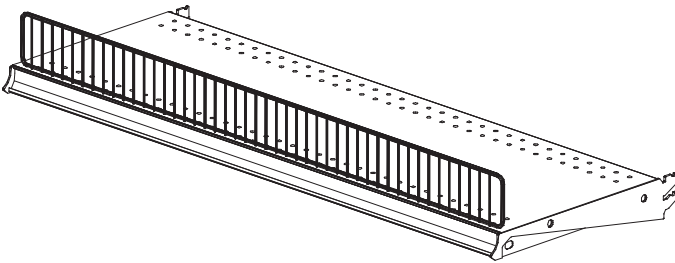

Wire Front Fence For Solid Shelf

Item #	L	H
99-5948-35XX004-??	36"	3"
99-5948-47XX004-??	48"	3"

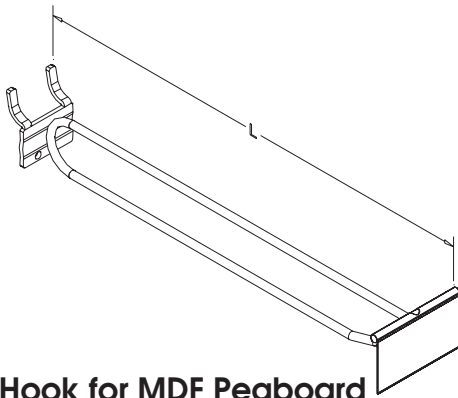

Peg Hook for MDF Pegboard

Item #	L
8470-04XXXXXX-33	4"
8470-06XXXXXX-33	6"
8470-08XXXXXX-33	8"
8470-11XXXXXX-33	11"

(Note: 33 = Galvanized finish)

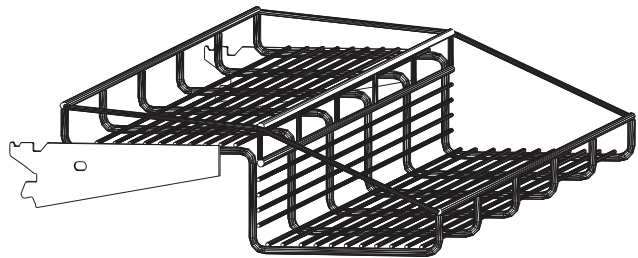

2-Tier Pastry Shelf

Item #	L	H
99-1840-3612005-??	36"	3"

(Note: ?? = 08 for Black or 15 for Sahara (beige))

Power Wing

Features:

- Attaches to end cap units
- 14”L x 4”D x 48”H
- Standard stock colors are Sahara (beige) and black
- Includes mounting clips and hardware.

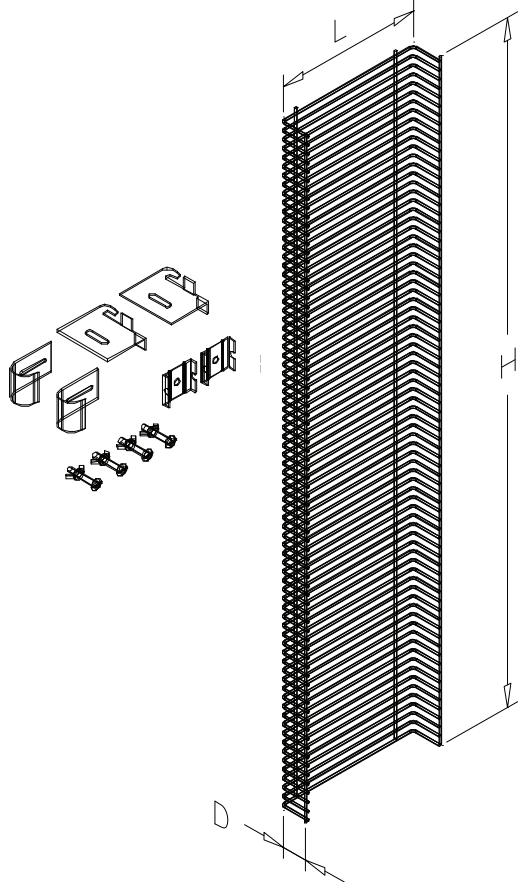

**Power Wing Merchandiser
(Attaches to End Cap unit)**

Item #	L	D	H
M??-PWHXXX-1404048-0	14”	4”	48”

Power Wing Shelf

Item #	L	D	H
2957-1305005-??	13”	4”	5”

(Note: ?? = 08 for Black or 15 for Sahara (beige))

Power Wing Hook

Item #	L
3200-04XXXXX-33	4”

(Note: 33 = Galvanized finish)

Power Wing Shelf

Features:

- 13”L x 4”D x 5”H
- Standard stock colors are Sahara (beige) and black

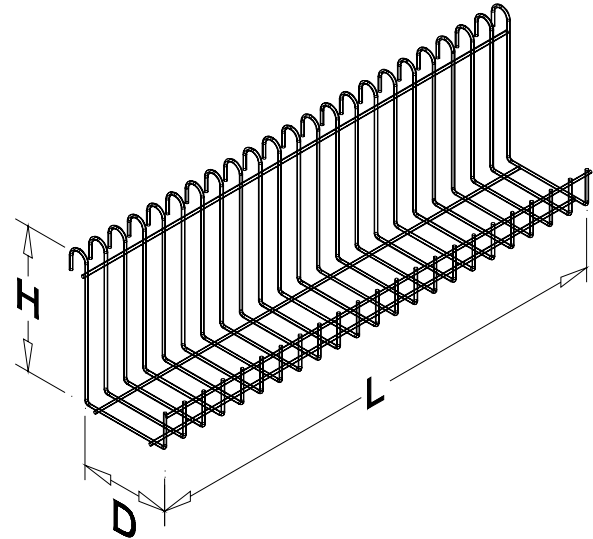

Power Wing Hook

Features:

- Length 4”
- Standard stock color is galvanized
- Includes label holder

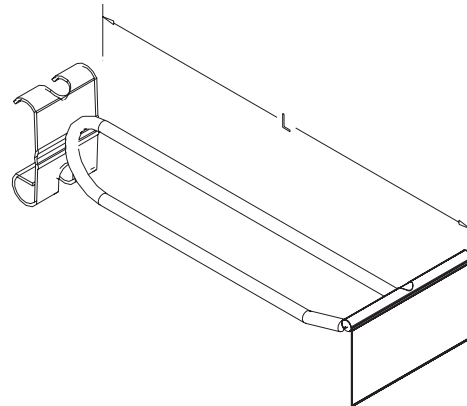

Madix Gondola System (by SHOPCO)

SHOPCO's Other Fine Products:

- Metal Beverage Cabinets
- Sales Counters

Metal Sales Counters:

- **Shop-Flex Metal Sales Counter:**

The Shop-Flex cabinet system is constructed of high quality powder coated metal components with an inter-locking design that permits the ultimate in versatility yet is so simple to assemble that it can be field installed in minutes. Our concept is to have a cabinet system with the durability of steel, the warmth and customization of wood, and the economy of mass production. Now you have a choice!

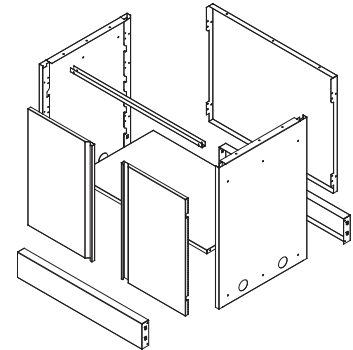

- **4D System Component Sales Counter:**

SHOPCO's 4D component sales counter system is designed to be a cost efficient way to obtain a durable metal counter with merchandising capability for a cost that is comparable to wood counters. The metal counter is designed to look like new for over 20 years, much longer than wood counters. This system also serves to promote impulse sales through the ability to add shelves to the cabinets for spot merchandising of impulse items. Better yet, the components are in stock and ready to ship in days (not weeks).

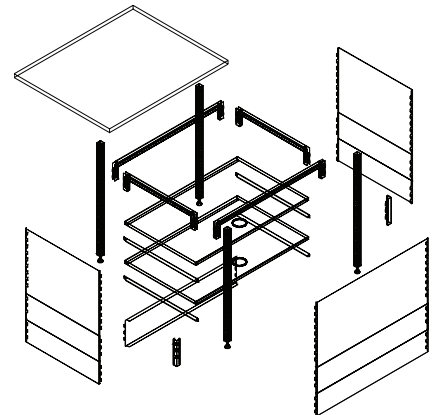

Metal Food Service Counters:

- **Metal Beverage Counter System:**

SHOPCO's metal cabinet system is far more durable and longer lasting than traditional wood cabinets, and has the advantage of being in stock in standard colors, in various configurations including straight prep units, trash units, built in cup dispensers, condiment trays or napkin dispensers, all in several lengths, three depths and available with any type of counter top from plastic laminate to stainless steel to solid surface or quartz.

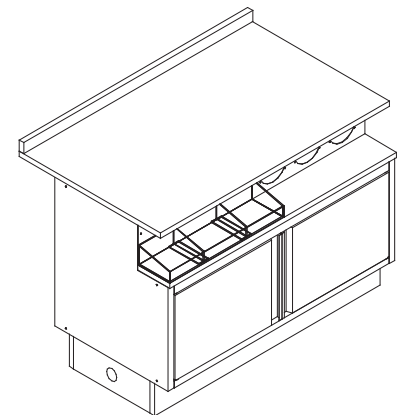

Let SHOPCO's design department create a complimentary new layout specifically designed for your store. We'll add functionality and create excitement to enhance your store's image while increasing impulse sales. SHOPCO can offer complete turn-key service from design, supply and installation to completely upgrade your store.

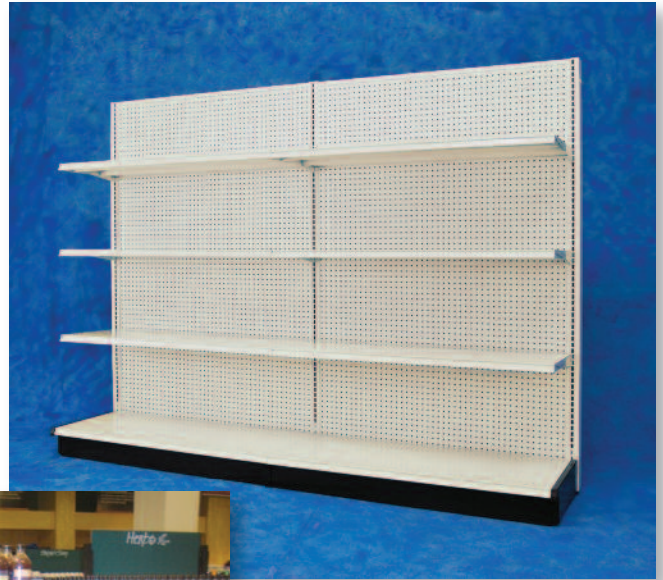

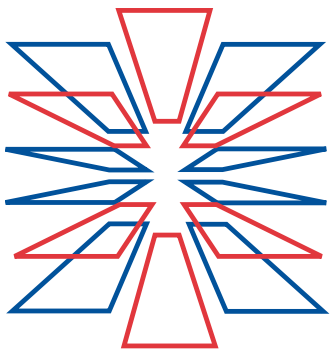

SHOPCO

The Merchandising System

SHOPCO U.S.A. Inc.

7171 W. Sam Houston Parkway North

Houston, Texas 77040

Telephone: 713/934-2900

Fax: 713/934-2929

Toll Free: 888/874-6726

Internet: www.shopcousa.com

