

# SHOPCO Metal Cabinet Product Catalog

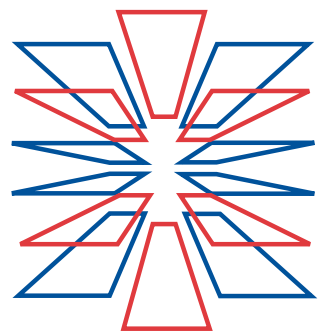

**SHOPCO**  
The Merchandising System

7171 West Sam Houston Pkwy. North  
Houston, TX 77040  
Toll Free: 888-874-6726  
Phone: 713-934-2900  
Fax: 713-934-2929  
[www.shopcousa.com](http://www.shopcousa.com)

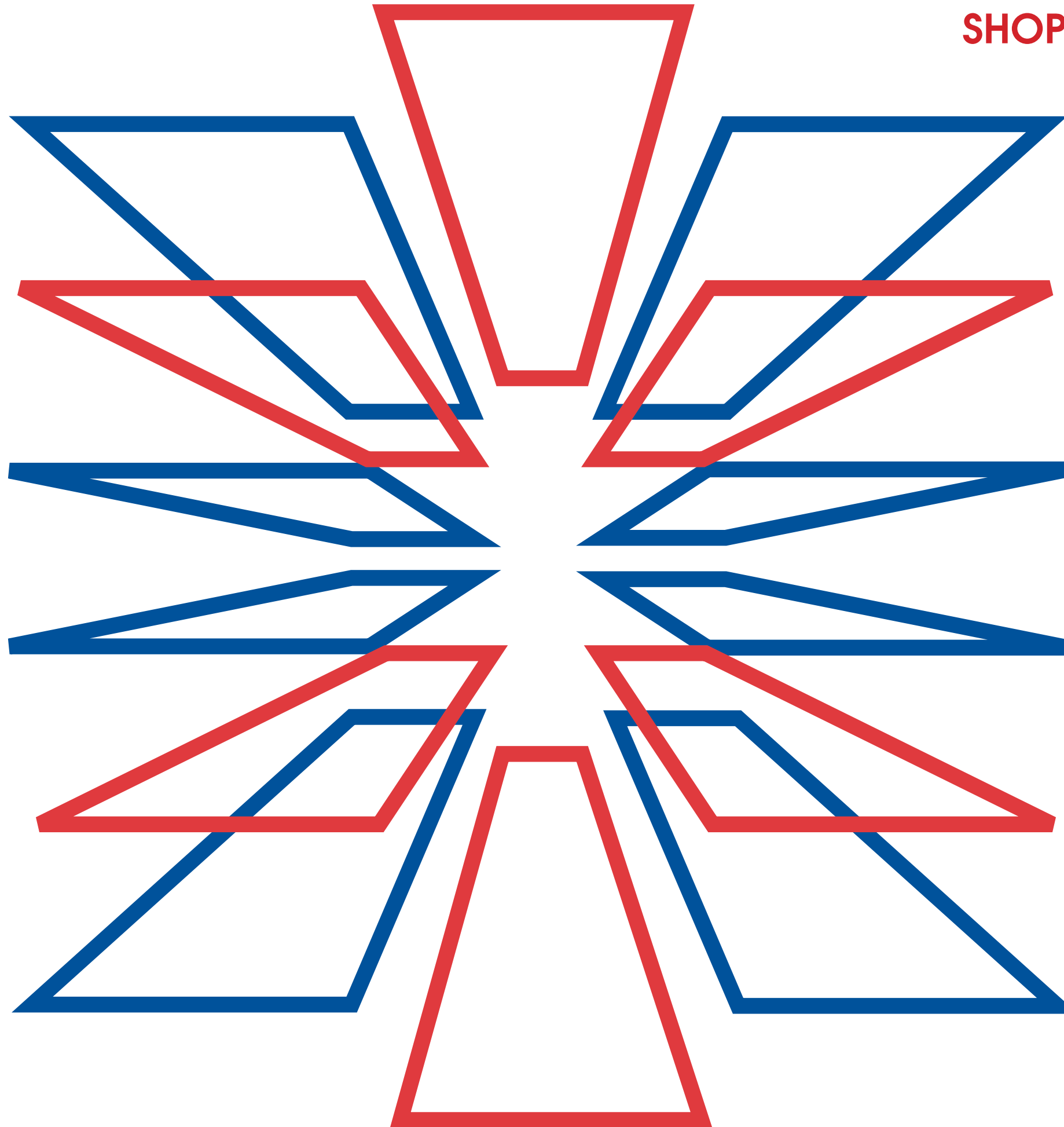

**SHOPCO**  
The Merchandising System

**SHOPCO Metal Cabinets** carry the same load capacities and qualities of traditional systems, but surpass these systems with the unique advantage of having their standard components in stock, ready-to-ship with no fabrication lead-time! The system is so flexible, merely swapping a few pieces rather than manufacturing an entire new cabinet body can change lengths, depths and cabinet style in minutes.

**Give SHOPCO a call today!**

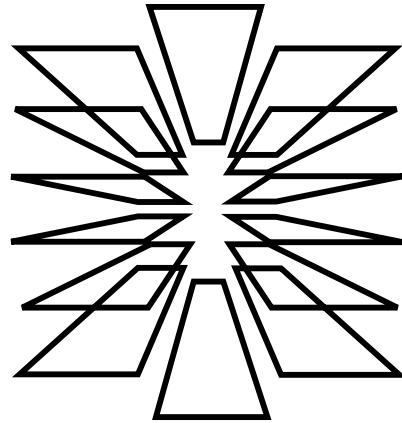

**SHOPCO's full service team can also assist you with:**

- Store interior layout and design
- Award-winning sales counters designed to promote impulse sales
- Unique all-metal merchandising fixtures, shelving and accessories
- Custom millwork and cabinetry, including solid surface countertops
- Turnkey service, including installation and equipment consolidation

Metal Features	2
Prep Units	3
Low Prep Units	4
Waste Units	5
Beverage Units	6
Condiment Units	8
Microwave Unit	9
Condiment Pedestal	10
Filler Panels	11
Accessories	13
Cabinet Dimension Drawings	15



**Component Style Fabrication Advantages:**

- Units typically ship assembled for ease of installation. However, they may be ordered as unassembled for reduced shipping costs.
- Quick ship availability, since components are stocked rather than fabricated per order
- Ease of on-site modifications without ordering an entire new cabinet
- Complete inventory of components stocked in white, black or beige
- Allows for easy custom powder-coating of non-standard colors
- Permits versatility unmatched in our industry

**Additional Features:**

- Variety of cabinet lengths and depths
- Standard cabinet bodies are 33" high including a 6" base, for a total cabinet height of 34" with a 1" thick counter top
- Wide variety of counter tops available, including plastic laminate, stainless steel and solid surface materials
- Removable base shelves and adjustable interior shelves
- Standard cabinets include back panels with openings to access electrical and plumbing chase (Optional back panel fillers are available)
- Counter tops fabricated per layout (not individual unit) to minimize seams
- Standard counter top design is 6" deeper than cabinet body to provide electric and plumbing chase behind unit
- Units come with standard 6" high metal base with four levelers for easy adjustment or optional stainless steel legs

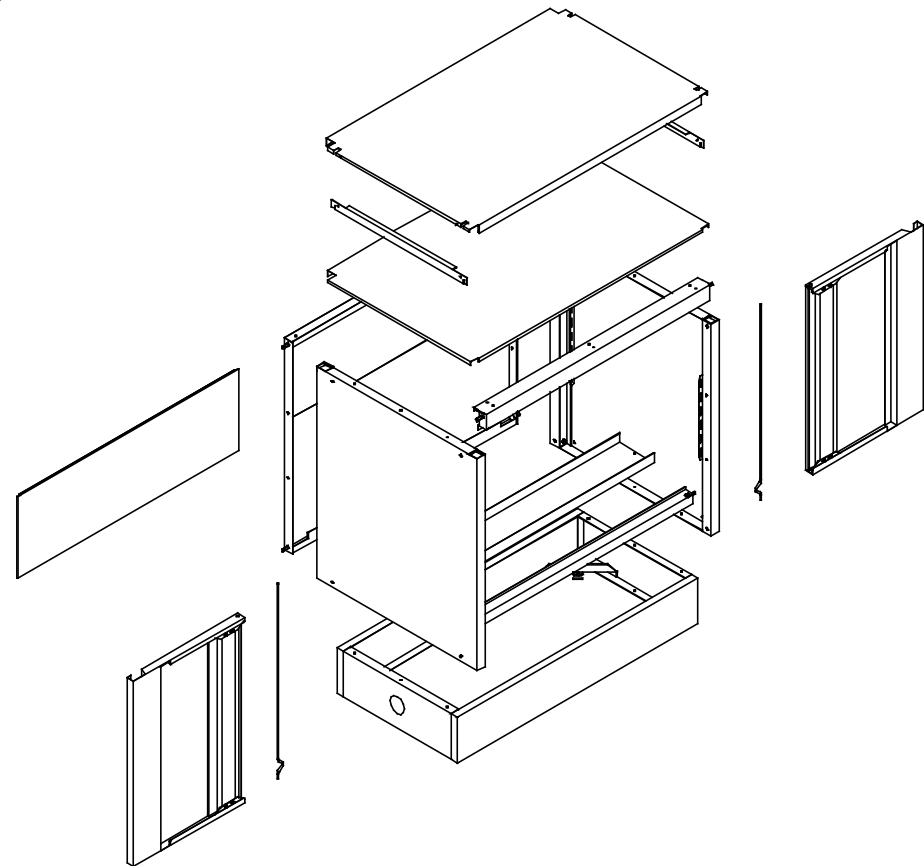

**Prep Unit Features:**

- Back panel with opening to access chase
- Optional filler for back panel opening
- One adjustable interior shelf
- One removable base shelf
- Cabinet body height - 33" (excluding counter top)
- Cabinet body depths - 18", 24", 30"
- Cabinet body lengths - 12", 18", 24", 30", 36" and 48"
- Standard counter tops are designed to provide a 5 1/2" electrical and plumbing chase behind cabinet
- Optional end filler panels available

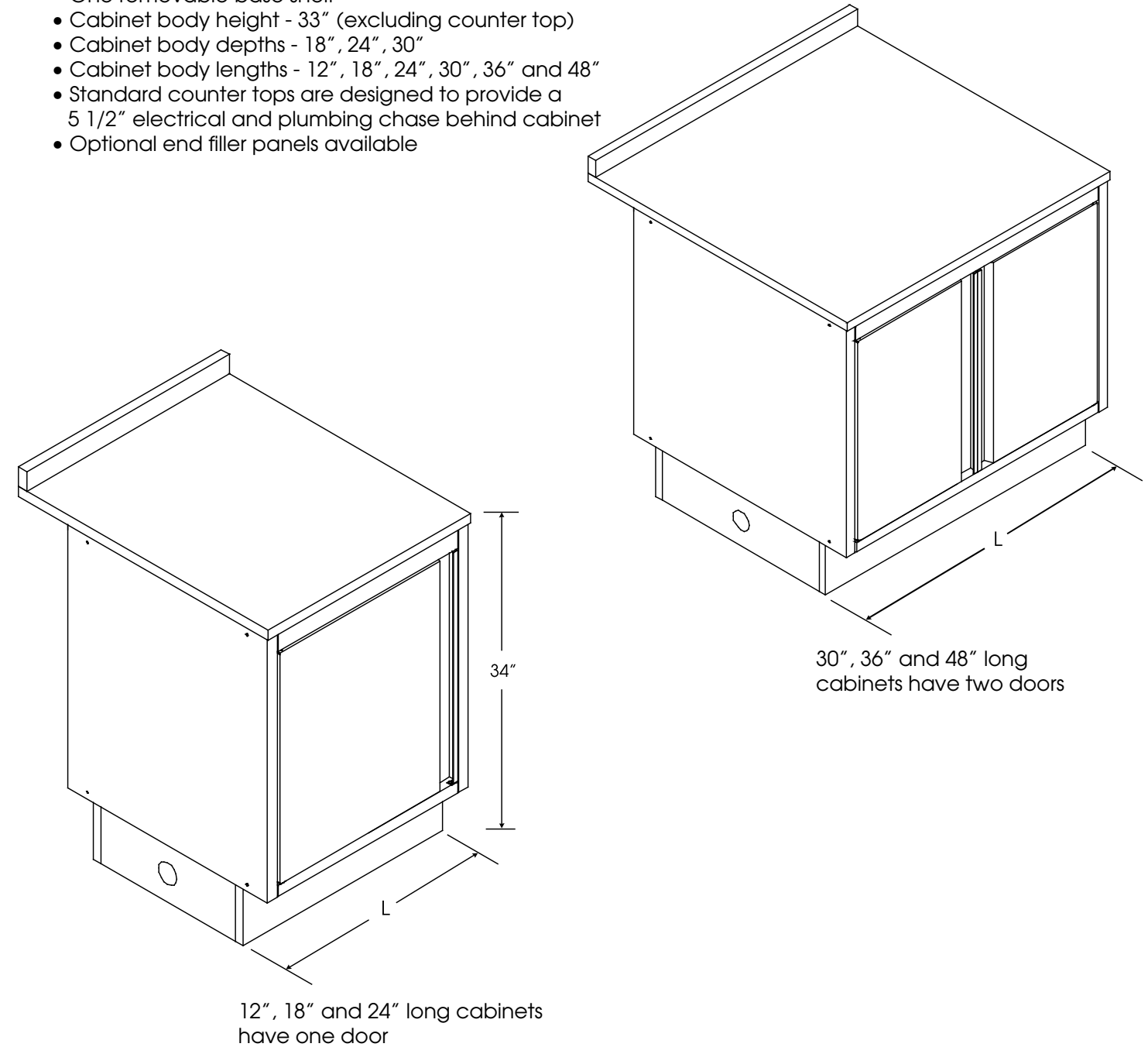

## Low Prep Units



### Low Prep Unit Features:

- Full back panel (with no chase access opening)
- One adjustable interior shelf
- One removable base shelf
- Cabinet body height - 25" (excluding counter top)
- Cabinet body depth - 18" and 24"
- Cabinet body length - 18", 24" and 36"
- Standard counter tops are designed to provide a 6" electrical and plumbing chase
- Optional end filler

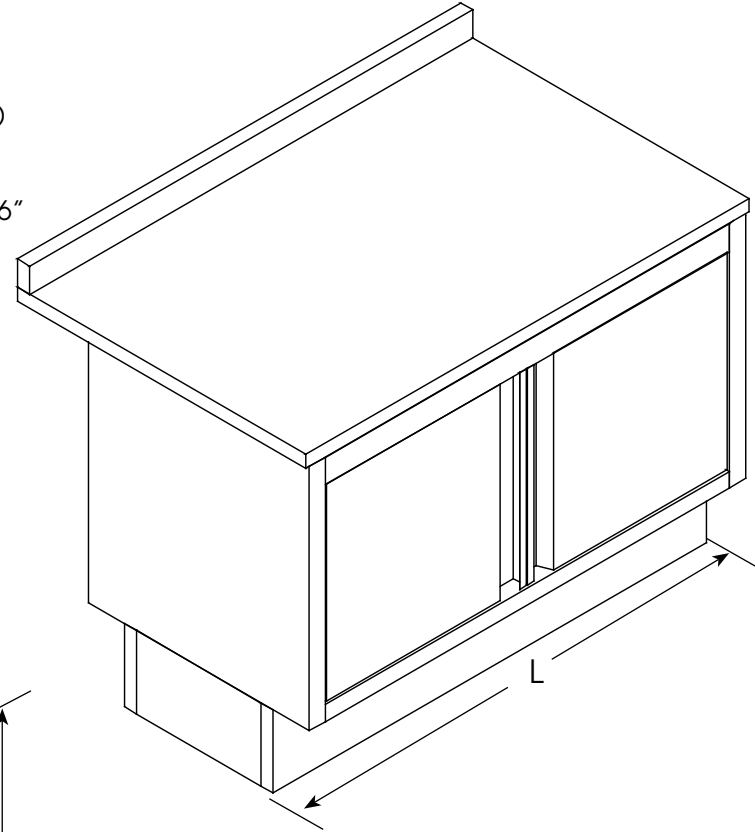

30", 36" and 48" long cabinets have two doors

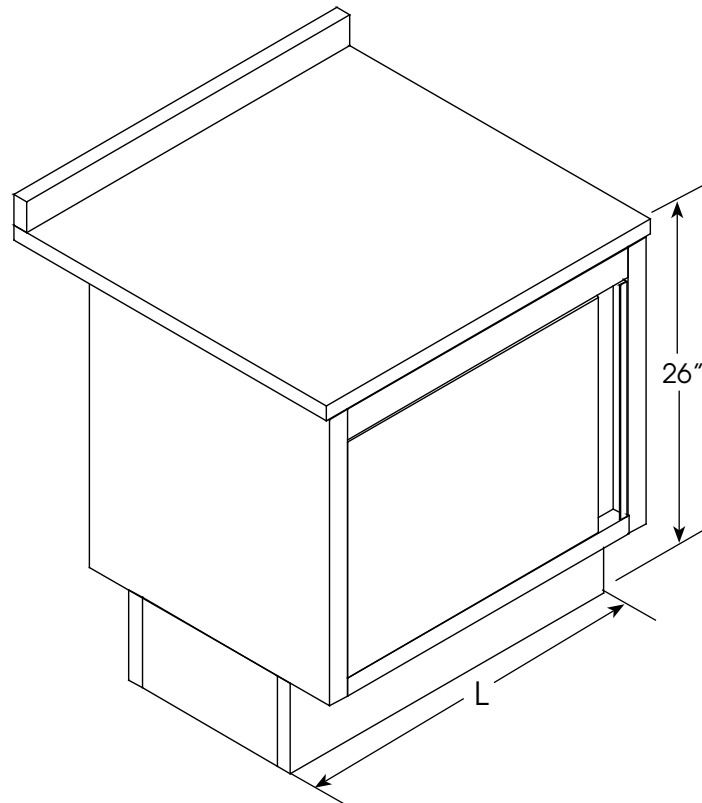

12", 18" and 24" long cabinets have one door



## Waste Units

### Waste Unit Features:

- One door and one trash flap
- Waste bin included (with stop for correct positioning of trash can)
- Removable base shelf
- Full back panel with no chase access opening
- Cabinet body height - 33" (excluding counter top)
- Cabinet body lengths - 12", 18", 24"
- Cabinet body depths - 24", 30"
- Standard counter tops are designed to provide a 5 1/2" electrical and plumbing chase
- Optional end filler panels available

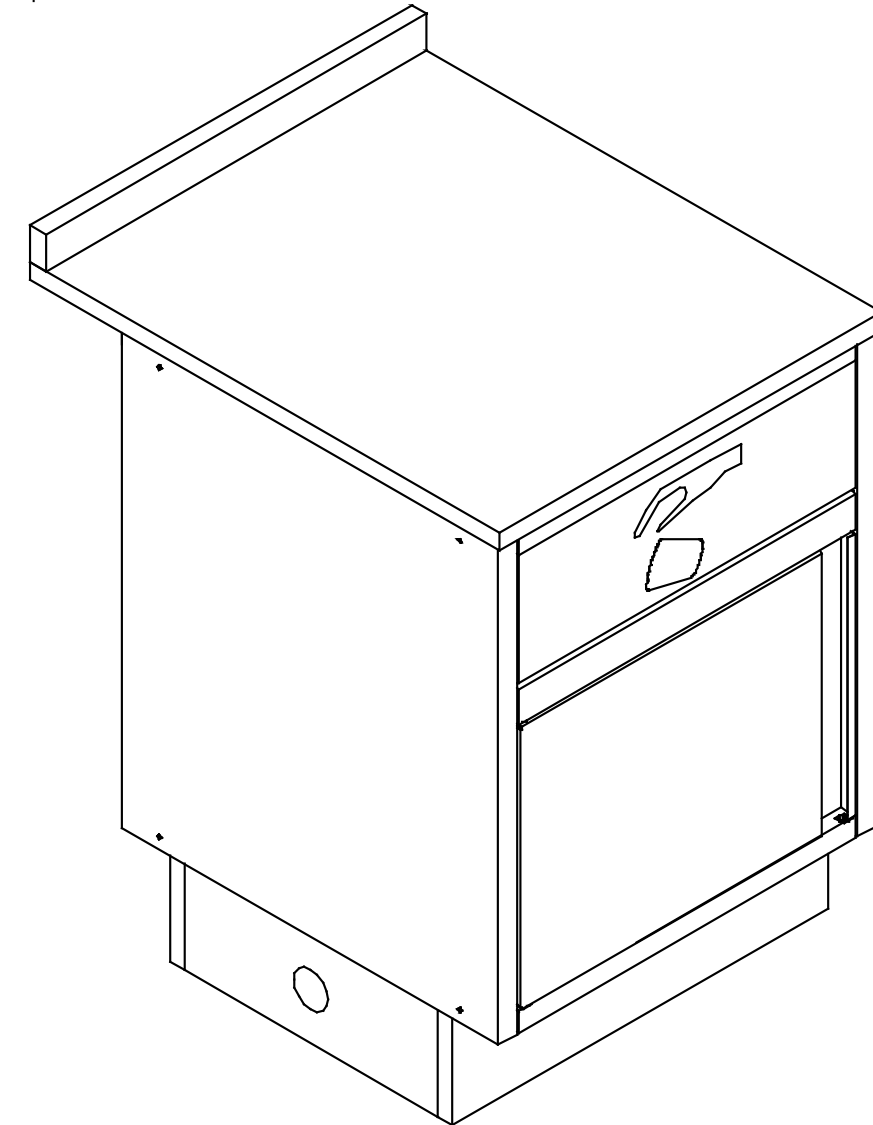



**Cup Dispenser Units**

**Features:**

- Stainless steel step ledge with cut-outs for cup dispensers
- Cup dispensers sold separately
- Internal support bar for cup dispensers is included
- Back panel with opening to access chase
- One removable base shelf
- Cabinet body height - 33" (excluding counter top)
- Cabinet body depths - 24" and 30"
- Cabinet body length - 24", 36" and 48"
- Heavy duty internal support optional for 36" length, standard for 48" length units
- Standard counter tops are designed to provide a 5 1/2" electrical and plumbing chase
- Optional end filler panels available

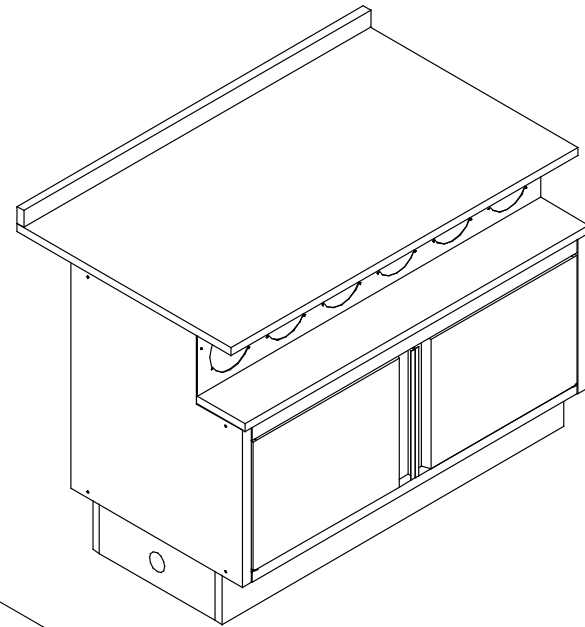

48" Long Unit  
6 cup dispenser openings

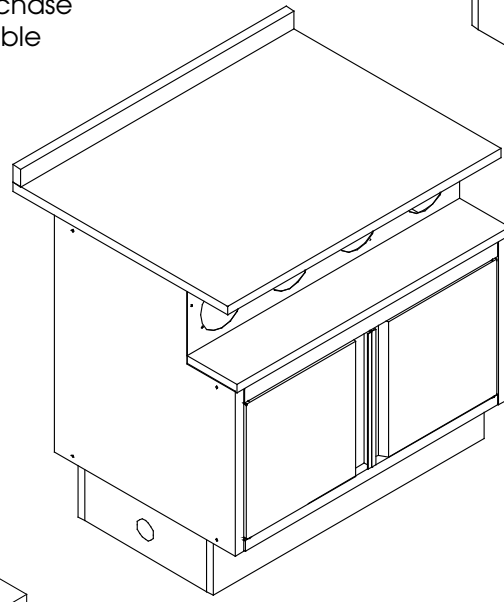

36" Long Unit  
4 cup dispenser openings

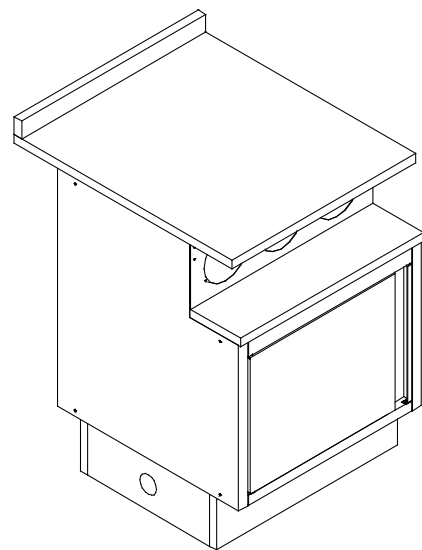

24" Long Unit  
3 cup dispenser openings



**Cup Dispenser plus Condiment Tray Unit**

**Features:**

- Stainless steel step ledge with cut-outs for cup dispensers, and positioning pins for acrylic condiment tray
- Cup dispensers sold separately
- Acrylic condiment tray included
- Internal support
- Back panel with opening to access chase
- One removable base shelf
- Cabinet body height - 33" (excluding counter top)
- Cabinet body depths - 24" and 30"
- Cabinet body lengths - 36", 48"
- Heavy duty internal support optional for 36" length, standard for 48" length
- Standard counter tops are designed to provide a 5 1/2" electrical and plumbing chase
- Optional end filler panels available

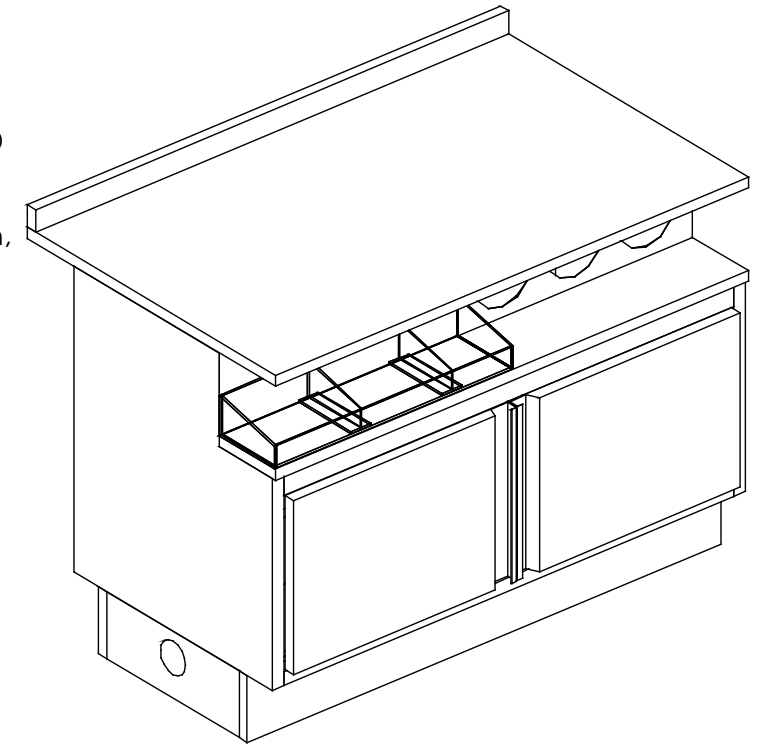

48" Long Unit  
3 cut-outs + 24" tray

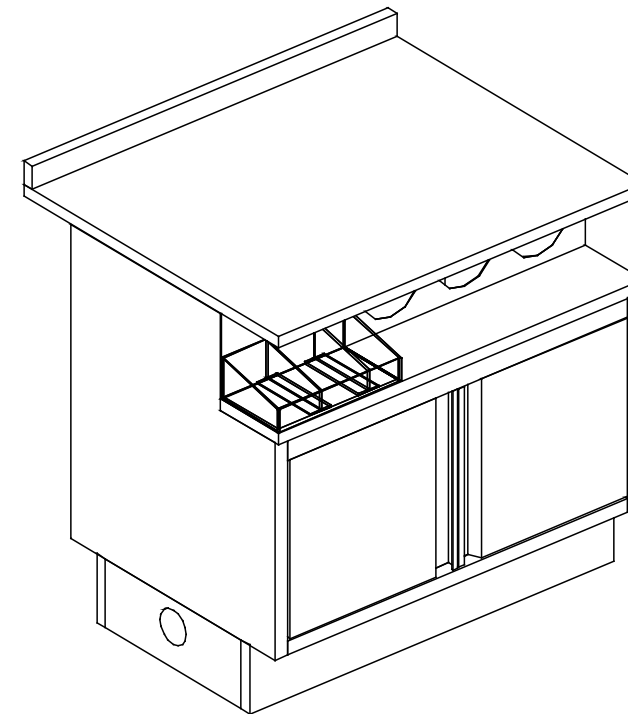

36" Long Unit  
3 cut-outs + 12" tray



**Condiment Unit Features:**

- With stainless steel step ledge and acrylic condiment tray
- Back panel with opening to access chase (optional filler for back panel opening available)
- One removable base shelf
- Cabinet body height - 33" (excluding counter top)
- Cabinet body length - 24", 36", 48"
- Cabinet body depths - 24", 30"
- Internal heavy duty support included in all 48" length units
- Special 48"L by 18"D unit available
- Standard counter tops are designed to provide a 5 1/2" electrical and plumbing chase
- Optional end filler panels available

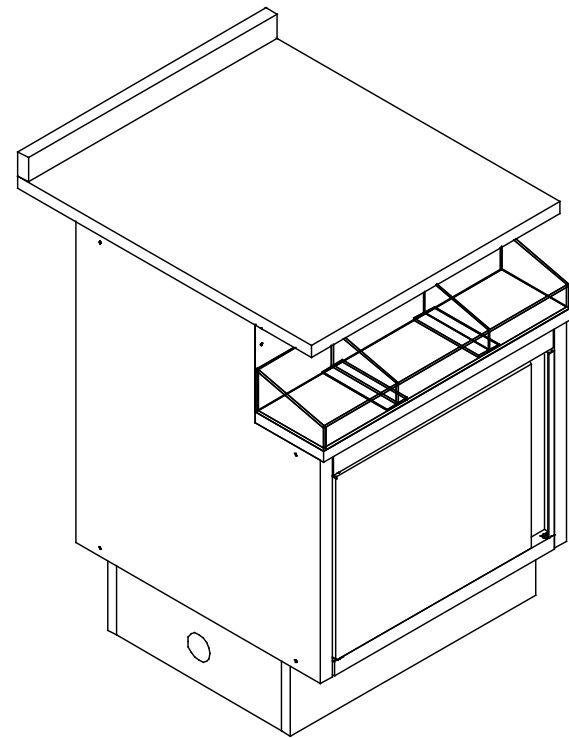

24" long cabinets have one door

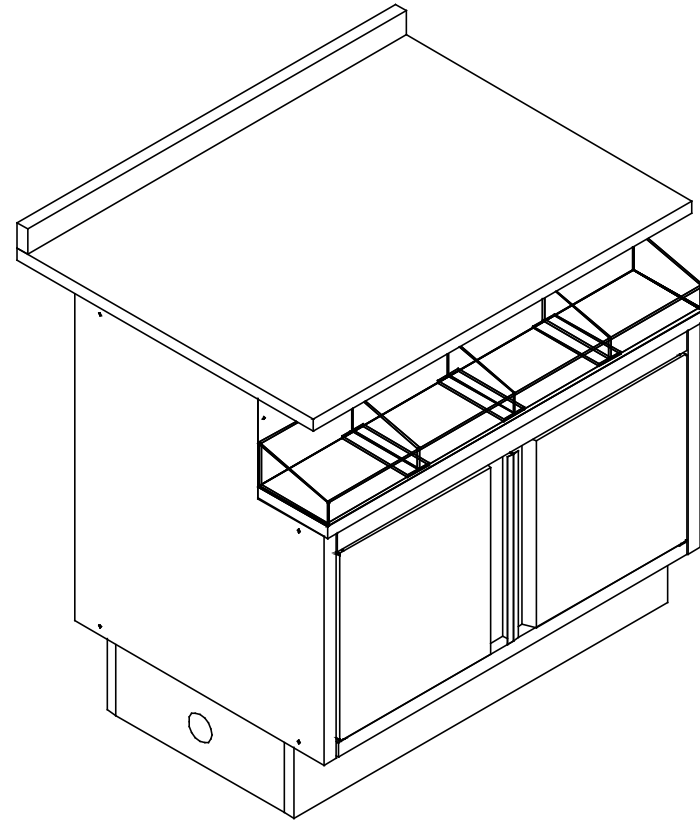

36" and 48" long cabinets have two doors



**Microwave Unit Features:**

- Back panel with opening to access chase (optional filler for back panel opening available)
- One storage drawer
- Interior shelf for microwave placement
- Cabinet body height - 33" (excluding counter top)
- Cabinet body length - 24"
- Cabinet body depth - 24"
- Clear opening for microwave cabinet is 22 1/8" w x 16 1/8" h x 20" d
- Standard counter tops are designed to provide a 5 1/2" electrical and plumbing chase
- Optional end filler panels available

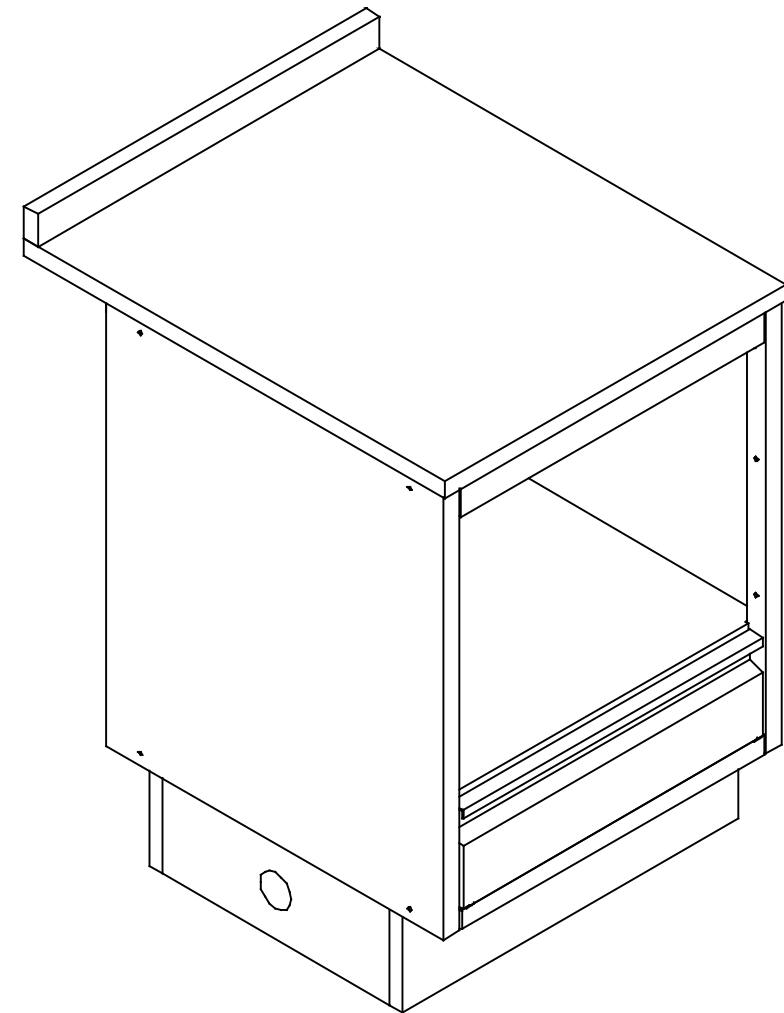



**Condiment Pedestal Features:**

- Four doors
- Two stainless steel trash flaps
- Two waste bins included
- Two stainless steel step ledges and acrylic condiment trays
- One interior adjustable shelf (in condiment section)
- Two removable base shelves
- Cabinet body height - 33" (excluding counter top)
- Cabinet body length - 36"
- Cabinet body depth - 30"

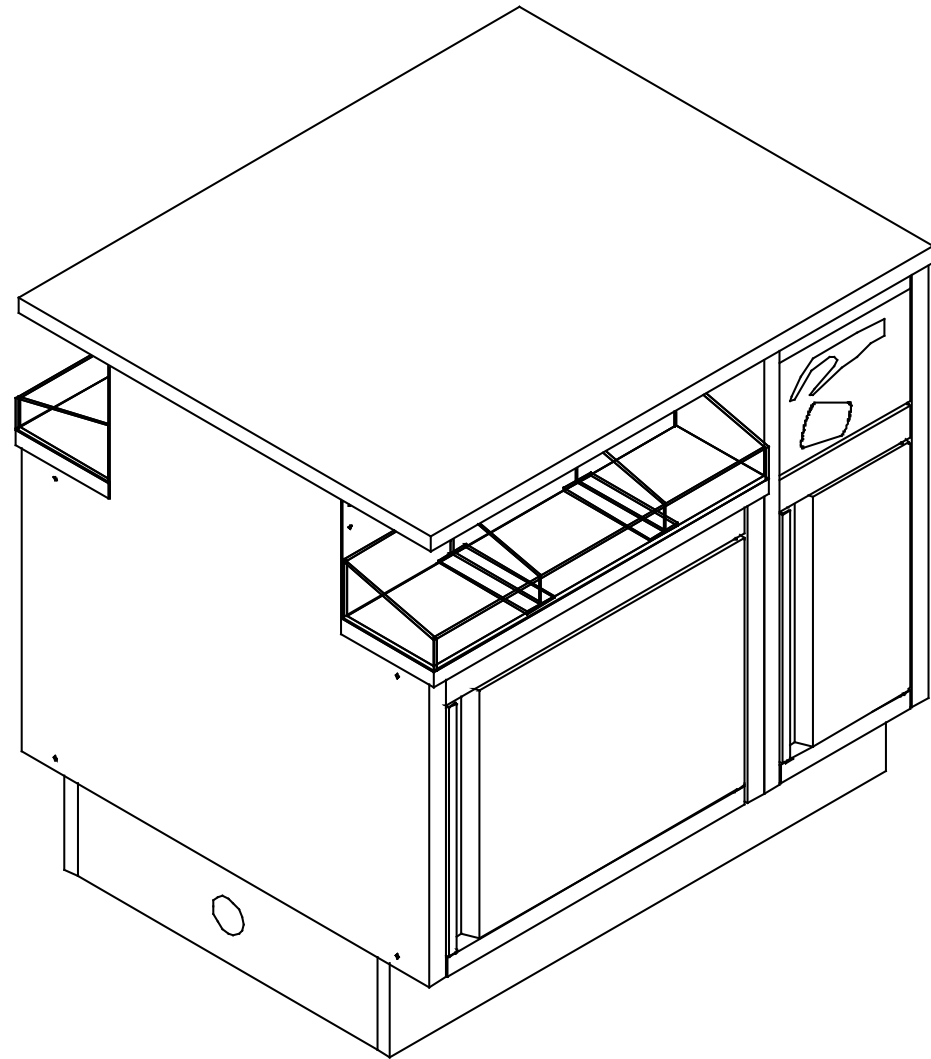

**45 Degree Filler Panel Features:**

- Designed to attach two units for an inside 45 degree corner
- Fills base and cabinet area

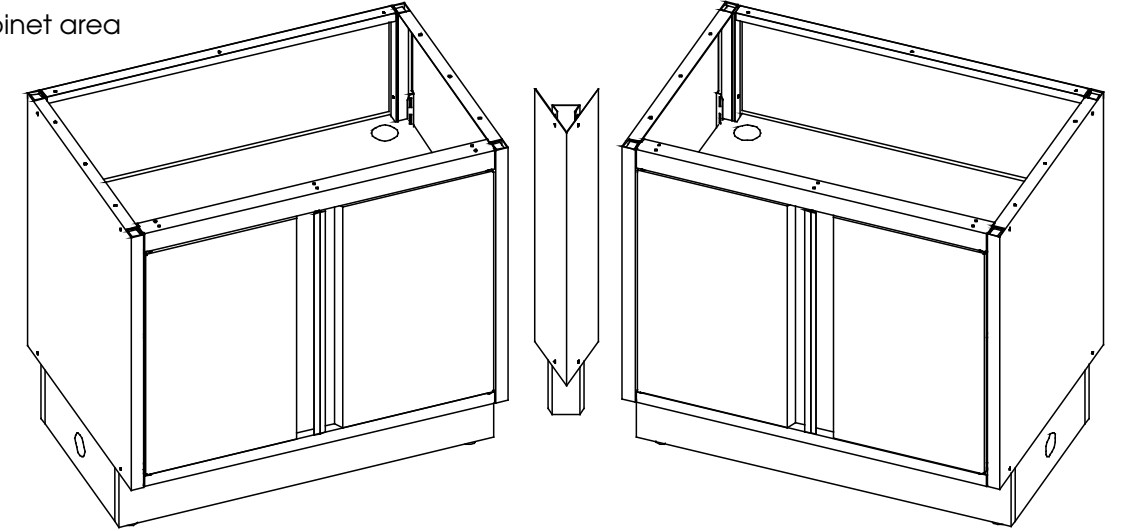

**90 Degree Filler Panel Features:**

- Designed to attach two units for an inside 90 degree corner
- Fills base and cabinet area

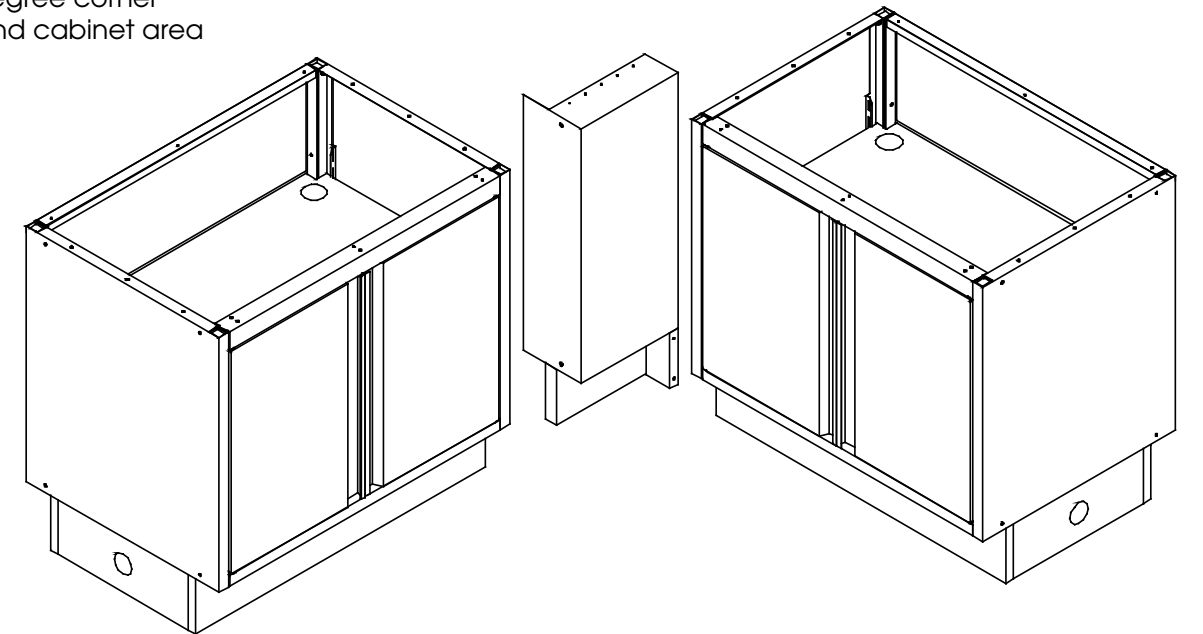

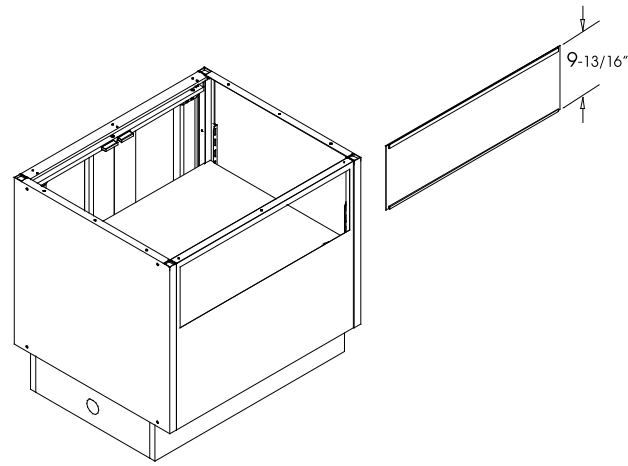

**Back Panel Filler Features:**

- To fill chase opening in back panel of cabinet
- Can be easily installed and removed from within the cabinet body

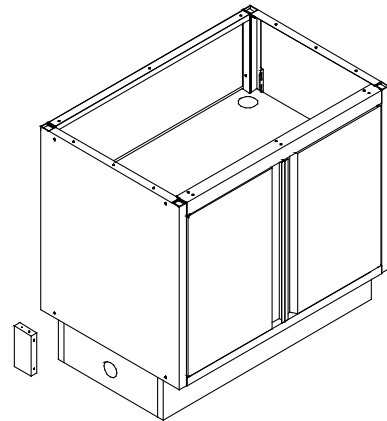

**Base Panel Filler Features:**

- To fill base opening between cabinet base and wall
- To be used in place of end filler for cabinets without chase

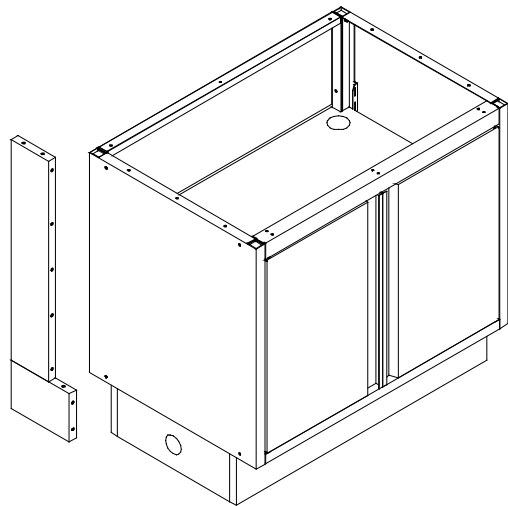

**End Filler Panel Features:**

- Designed to finish off the opening of a standard 5 1/2" chase
- Finishes base and cabinet area at the end of a run

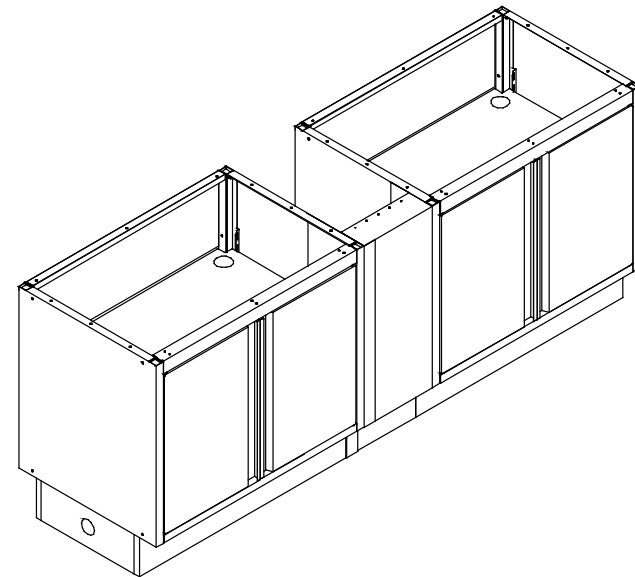

**Adjustable Filler Panel Features:**

- Designed to complete a cabinet run unequal to length of standard cabinet bodies
- \* Easily cut to size in field; adjustable from 2" to 12" in length
- Unique design provides finished edges after cutting to correct size

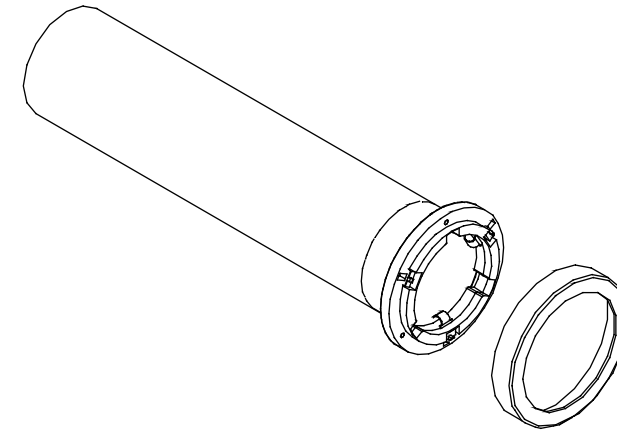

**Cup Dispenser:**

- One-size-fits-all adjustable cup dispenser utilizes a three clip design for a variety of paper, plastic and foam cups. The fingers can be adjusted to fit 8 oz. to 44 oz. size cups without having to be removed from the cabinet.

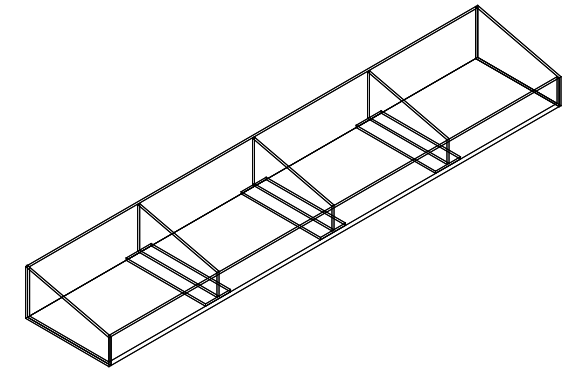

**Condiment Tray:**

- 6" deep
- Includes adjustable dividers for various condiment items
- Tray lengths - 12", 24", and 36"

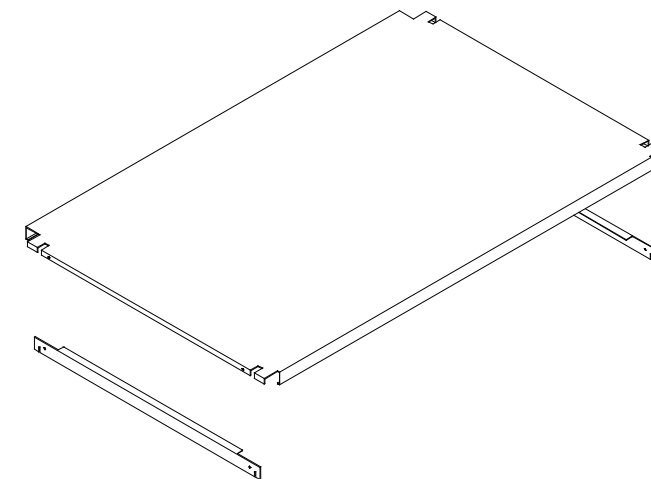

**Adjustable Interior Shelf:**

- Requires two brackets



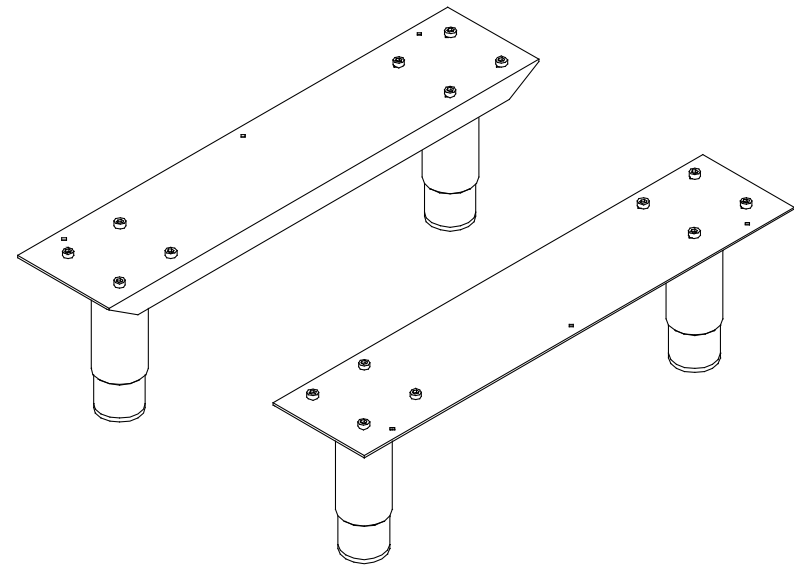

**Stainless Steel Legs:**

- To be used in place of standard base when desired
- Height is adjustable from 5.5" to 9.5"

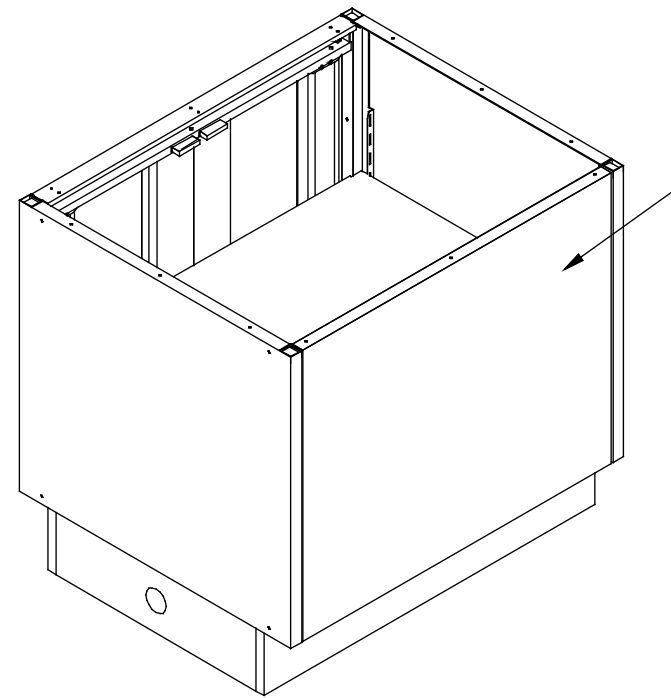

**Full Back Panel:**

- Back panel without chase opening
- Available for all cabinet sizes
- Supplied standard on trash units

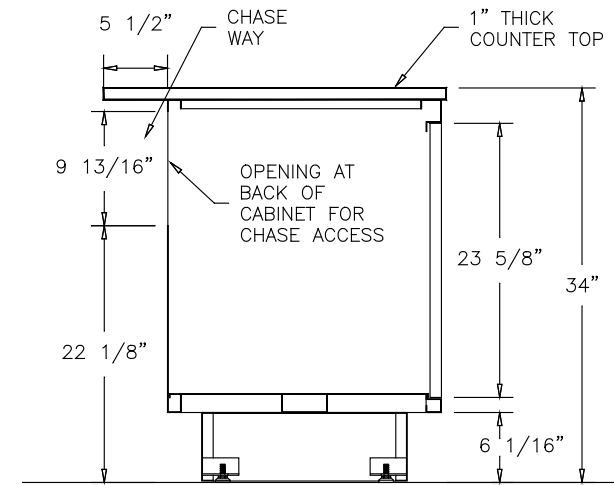

**STANDARD PREP UNIT**

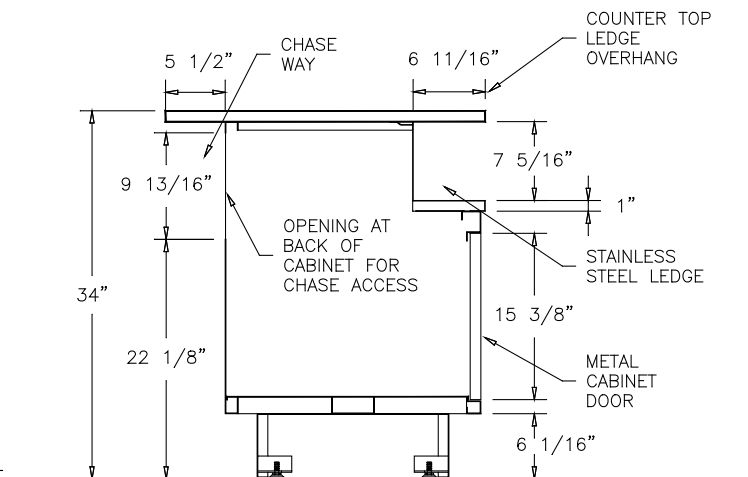

**BEVERAGE UNIT**

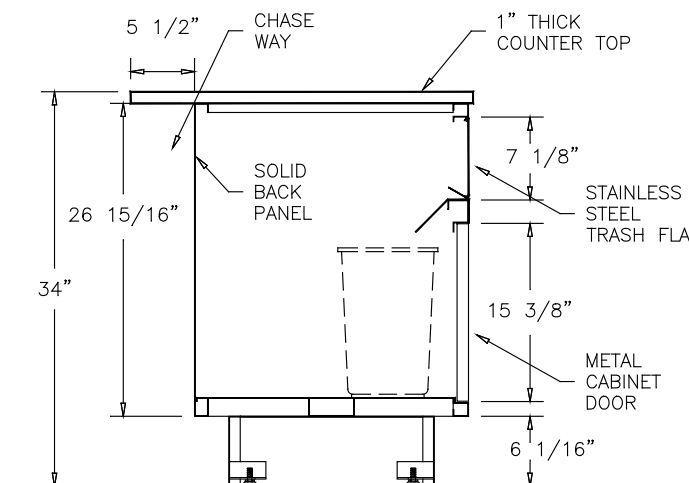

**TRASH UNIT**

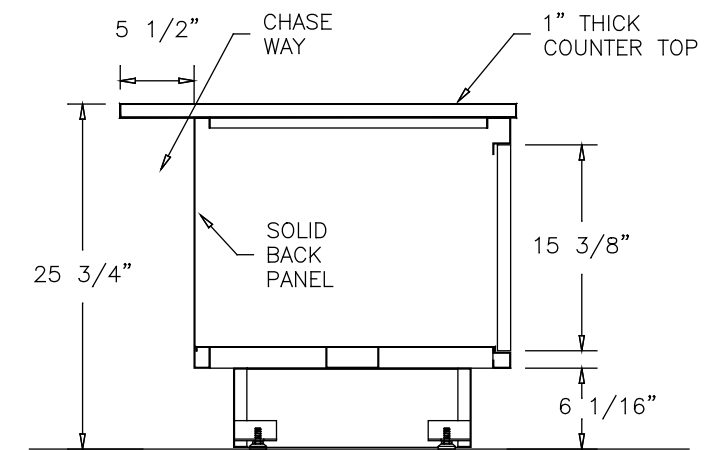

**LOW PREP UNIT**

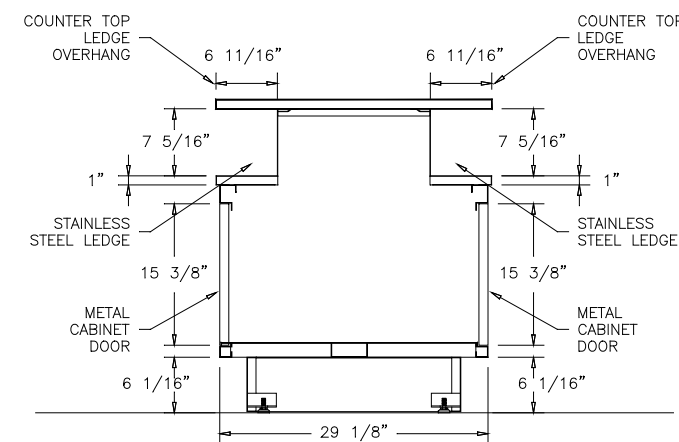

**CONDIMENT PEDISTAL**

ACTUAL CABINET LENGTHS	
NOMINAL LENGTH	ACTUAL LENGTH
12"	11-13/16"
18"	17 - 3/4"
24"	23 - 5/8"
30"	29 - 1/2"
36"	35 - 7/16"
48"	47 - 1/4"



With SHOPCO's complimentary design service, our design department can create an exciting new Metal Cabinet layout that is customized to fit your store's specific requirements.

Our design department not only creates entire new store layouts, but can also retrofit your existing store in order to provide a functional design with a contemporary upscale look and feel.

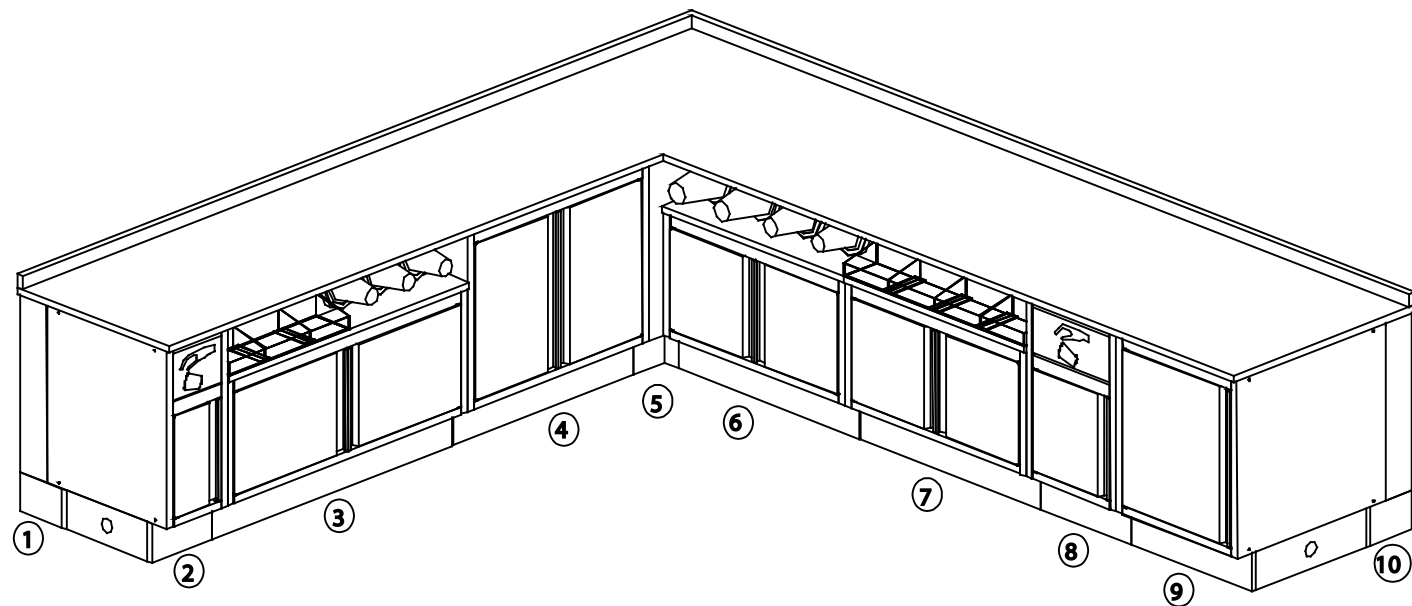

- |  |                                      |
|--|--------------------------------------|
| 1) End Filler Panel                                | 6) 36" L X 30" D 4 Cup Beverage Unit |
| 2) 12" L X 24" D Waste Unit                        | 7) 36" L X 30" D Condiment Unit      |
| 3) 48" L X 24" D 3 Cup and Condiment Beverage Unit | 8) 18" L X 30" D Waste Unit          |
| 4) 36" L X 24" D Prep Unit                         | 9) 24" L X 30" D Prep Unit           |
| 5) 90 Degree Filler Panel                          | 10) End Filler Panel                 |



### Take Advantage of Our Complimentary Design Service!

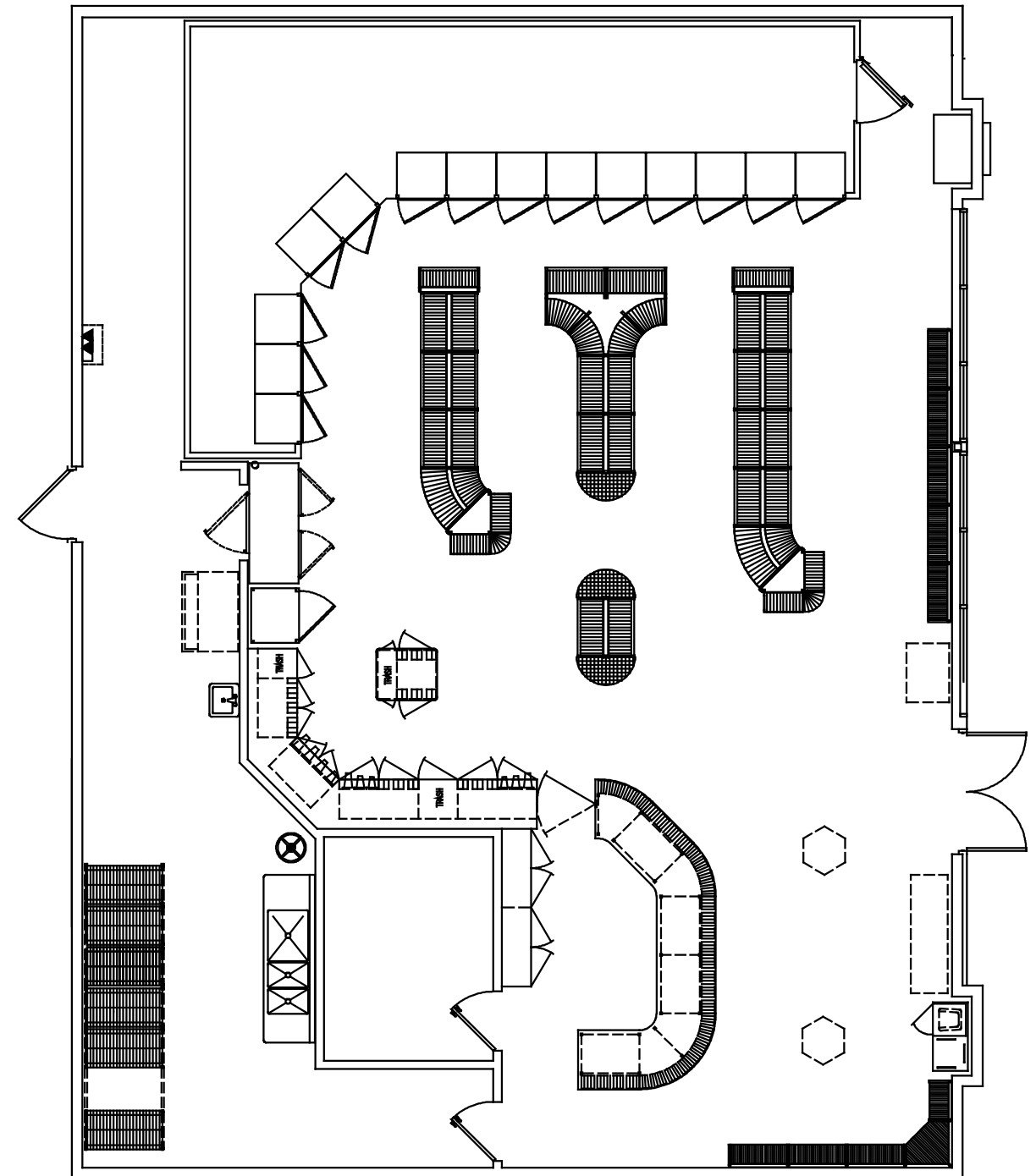

SHOPCO's extensive experience in design has proven that certain design parameters have a major impact on sales and profitability.