



SHOPCO USA

**We build stores
that thrive**

Catalog

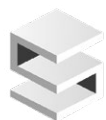

Table of Contents

A Letter From Our Owners	1
Customize Your Fixtures	2
S2g Shopco 2 nd Generation Metal Cabinets	3
Madix Gondola Systems	14
Specialty Fixtures	24
Tobacco Fixtures	25
Design Services	26



With Over 400 Years of Experience, Our Team is **Ready to Serve You!**





A Letter From Our Owners

WELCOME!

Thank you for taking the time to consider **SHOPCO USA** for your store fixture needs! At **SHOPCO**, we are dedicated to providing our customers with the best experience possible. **SHOPCO** was founded in 1985 with the philosophy of serving our customers with premium products, innovative designs, superior customer service, and the shortest lead time in the industry.

We take pride in our high-quality, versatile, and long-lasting retail merchandising systems, including Metal Food Service Cabinets, Metal Sales Counters, Tobacco Fixtures, and Gondola Shelving Systems. Over the years, we've grown to be one of the leading fixture suppliers to the retail marketplace, focused on convenience stores, travel centers, liquor stores, tobacco outlets, and more.

As our product line continues to grow, our values remain the same. We strive to remain the marketplace leader through unparalleled product design, continual research and development, creative store concepts, and a team of employees who are passionately committed to exceeding the customer's expectations daily. Providing customers with the shortest lead time in the store fixture industry is just one of many elements contributing to our superior customer service.

We invite you to browse through this product catalog and examine the many ways we can assist with your store remodel projects or new build designs. You will find examples of the award-winning designs possible with our unique component system. Our professional sales team and creative designers are waiting to help design your store with the limitless possibilities of our all-metal system, designed to enhance a store's image, increase impulse sales, and last for decades to come.

Please feel free to contact us at www.shopcousa.com or call us at **(713) 934-2900**. We invite you to **"Come and Discover the SHOPCO Difference!"**

Sincerely,
A Letter From Our Owners

DAVID BIRD
Owner

SAM GLENNEY
Owner

NEIL KELLER
Owner

MICHAEL SHUTTLESWORTH
Owner



Customizing Your Fixture Solutions

For over 35 years the SHOPCO Team have been working with all retail channels to provide the most versatile, yet durable and aesthetically pleasing interior store fixtures. If you are looking for a true partnership for your in-store fixture needs that will take the time to understand your business needs, and form a relationship far beyond the sale itself, then SHOPCO is the company of choice! Regardless of your business type, SHOPCO has an interior fixture solution for you!

SHOPCO has developed an array of all-metal fixture systems to meet your design requirements for gondola merchandising, food and beverage counter solutions, the all important sales counter presentation, tobacco fixtures and many other specialty fixtures to achieve all your merchandising goals.

Combine these spectacular fixtures with our remarkable sales staff, AutoCAD design offering and first class customer service, and you will have everything you need to win the merchandising “battle”.

METALING IN MERCHANDISE

- Award-winning, all-metal sales counters designed not only to increase impulse sales, but also to be team member friendly.
- The Metal Cabinet System, stocked for immediate shipment for quick serve food counter and beverage solutions.
- SHOPCO is proud to offer Madix products and SHOPCO is one of a only a few Master Distributors of Madix product in the United States. Madix fixtures are manufactured in a highly automated facility with the most Modern technology to create store fixtures that are as cost efficient as they are functional.
- Industry’s shortest lead-time on product offerings.
- Made to order custom counter tops and specialty fixtures.
- Unbeatable SHOPCO service (sales support, CAD Design, supply and installation).
- National In-House Installation Team.
- Partnered with Image Works Tobacco Fixtures for your Fixture needs.



S2G Shopco 2nd Generation Metal Cabinets

SHOPCO's Metal Food Service Counters carry the same load capacities and qualities of traditional systems, but surpass these systems with the unique advantage of being in stock, ready-to-ship with no fabrication lead time! SHOPCO's Metal Food Service Counters System utilizes a variety of units to create a Counter sequence that meets your specific retail needs. We offer a full line of all metal Counters with options such as prep units, waste units, beverage units, condiments units, and microwave units.

All units are stocked in white, beige, and black. Counter top fabrications are also available through SHOPCO: Solid Surface, Plastic Laminate and Stainless Steel. In addition, you also have the choice of stainless-steel legs or metal bases. The all-metal components provide limitless design opportunity, while maintaining the durability and cleanliness of powder-coated metal, which makes the Metal Cabinet System ideal for QSR and retail food service applications. The system is so flexible, merely swapping a few pieces can change the lengths, depths and Counters style in minutes.





S2G Metal Cabinets

CUSTOM STYLE FABRICATION ADVANTAGES:

- Units typically ship assembled for ease of installation. However, they may be ordered unassembled for reduced shipping costs.
- Quick ship availability, since components are stocked rather than fabricated per order.
- Ease of on-site modifications without ordering an entire new cabinet.
- Complete inventory of components stocked in black, beige and white.
- Allows for easy custom powder-coating of non-standard colors.
- Permits versatility unmatched in our industry.

ADDITIONAL FEATURES:

- Variety of cabinet lengths and depths.
- Standard cabinet bodies are 33" high including a 5" base, for a total cabinet height of 34" with a 1" thick counter top.
- Wide variety of counter tops available, including plastic laminate, stainless steel and solid surface materials.
- Removable base shelves and adjustable interior shelves.
- Standard cabinets include back panels with openings to access electrical and plumbing chase (Optional back panel fillers are available).
- Counter tops fabricated per layout (not individual unit) to minimize seams.
- Standard counter top design is deeper than cabinet body to provide electric and plumbing chase behind unit.
- Units come with standard high metal base with four levelers for easy adjustment or optional stainless steel or powder-coated legs.
- Many design options are available, such as plastic laminate on doors and/or custom doors.

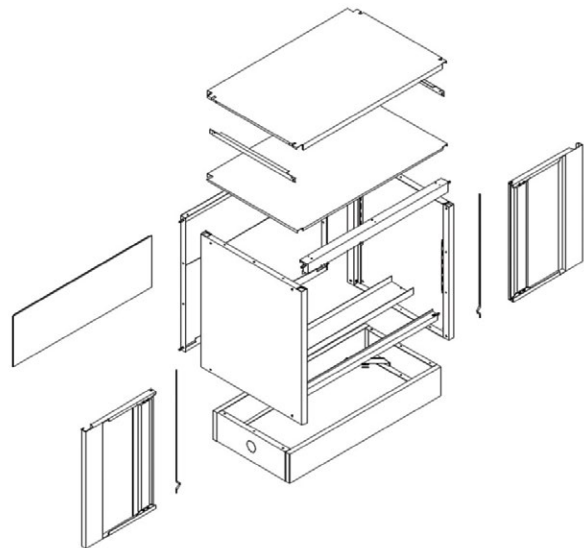



S2G Metal Cabinets

PREP UNIT FEATURES:

- Back panel with opening to access chase
- Optional filler for back panel opening
- One adjustable interior shelf
- One removable base shelf
- Cabinet body height - 33" (excluding counter top)
- Cabinet body depths - 18", 24", 30", 36"
- Cabinet body lengths - 12", 18", 24", 30", 36" and 48"
- Standard counter tops are designed to provide a 5 1/2" electrical and plumbing chase behind cabinet
- Optional end filler panels available

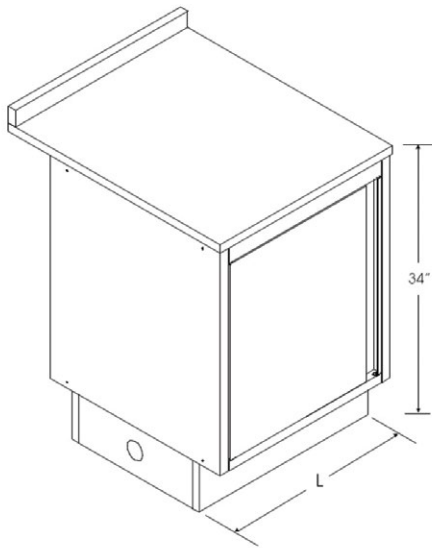

12", 18" AND 24" LONG
CABINETS HAVE ONE DOOR

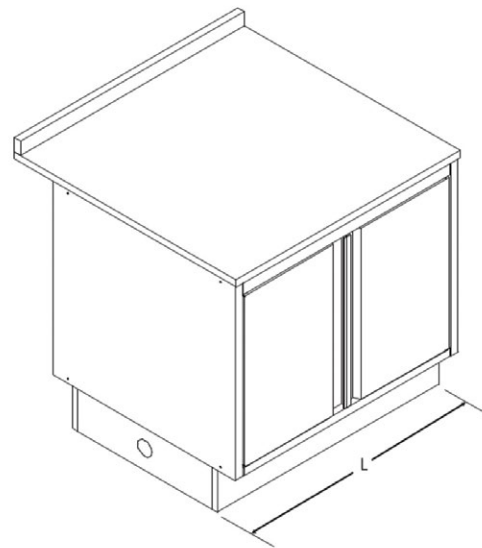

30", 36" AND 48" LONG
CABINETS HAVE TWO DOORS



S2G Metal Cabinets

LOW PREP UNIT FEATURES:

- Full back panel (with no chase access opening)
- One adjustable interior shelf
- One removable base shelf
- Cabinet body height - 25" (excluding counter top)
- Cabinet body depth - 18" and 24"
- Cabinet body length - 24", 36" and 48"
- Standard counter tops are designed to provide a 5.5" electrical and plumbing chase
- Optional end filler

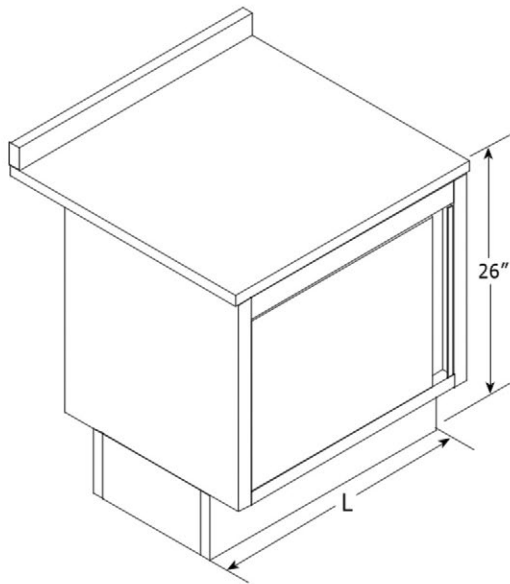

24" LONG CABINET
HAS ONE DOOR

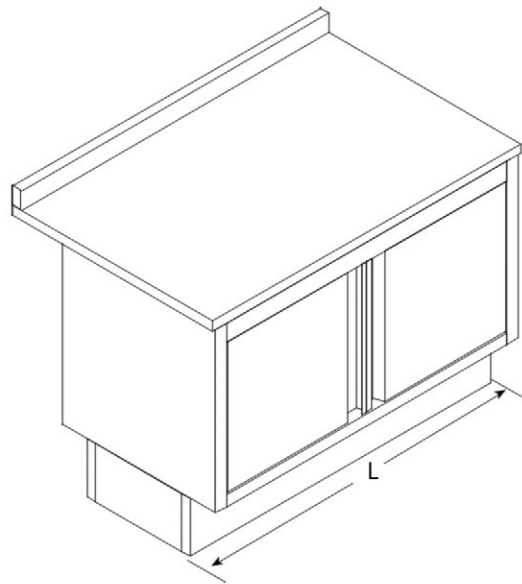

36" AND 48" LONG
CABINETS HAVE TWO DOORS



S2G Metal Cabinets

WASTE UNIT FEATURES:

- One door and one stainless steel trash flap
- Waste bin included (with stop for correct positioning of trash can)
- Removable base shelf
- Full back panel with no chase access opening
- Cabinet body height - 33" (excluding counter top)
- Cabinet body lengths - 12", 18" and 24"
- Cabinet body depths - 24" and 30"
- Standard counter tops are designed to provide a 5 1/2" electrical and plumbing chase
- Optional end filler panels available

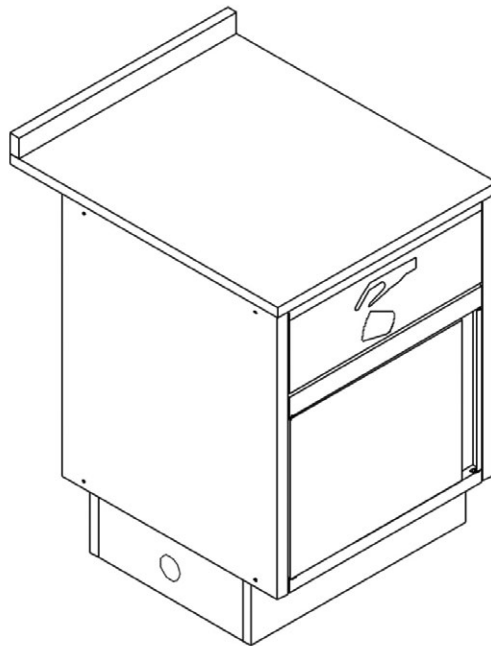



S2G Metal Cabinets

CUP DISPENSER UNITS FEATURES:

- Stainless steel step ledge with cut-outs for cup dispensers
- Cup dispensers sold separately
- Internal support bar for cup dispensers is included
- Back panel with opening to access chase
- One removable base shelf
- Cabinet body height - 33" (excluding counter top)
- Cabinet body depths - 24", 30" and 36"
- Cabinet body length - 24", 36" and 48"
- Heavy duty internal support optional for 36" length, standard for 48" length units
- Standard counter tops are designed to provide a 5 1/2" electrical and plumbing chase
- Optional end filler panels available

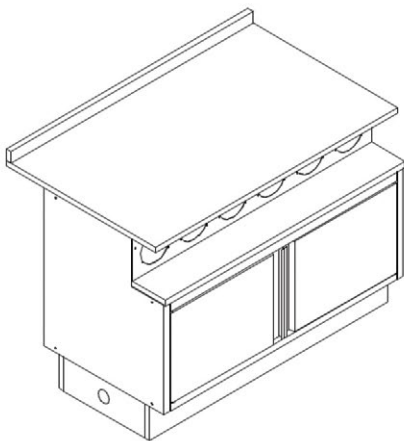

48" LONG UNIT
6 CUP DISPENSER OPENINGS

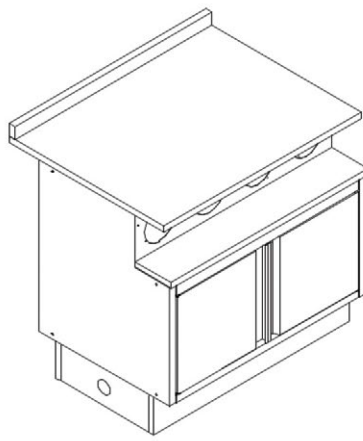

36" LONG UNIT
4 CUP DISPENSER OPENINGS

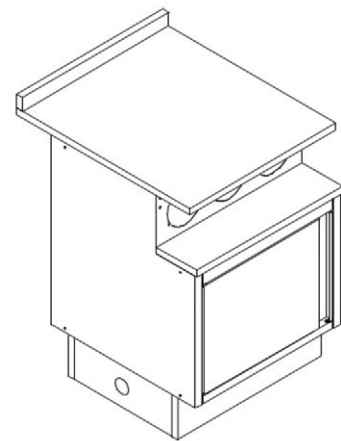

24" LONG UNIT
3 CUP DISPENSER OPENINGS



S2G Metal Cabinets

MICROWAVE UNIT FEATURES:

- Back panel with opening to access chase (optional filler for back panel opening available)
- One storage drawer
- Interior shelf for microwave placement
- Cabinet body height - 33" (excluding counter top)
- Cabinet body length - 24"
- Cabinet body depth - 24"
- Clear opening for microwave cabinet is 22 1/8" w x 16 1/8" h x 20" d
- Standard counter tops are designed to provide a 5 1/2" electrical and plumbing chase
- Optional end filler panels available

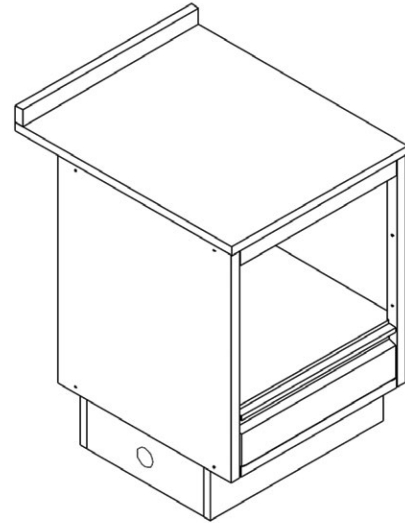

45 DEGREE FILLER PANEL FEATURES:

- Designed to attach two units for an inside 45 degree corner
- Fills base and cabinet area

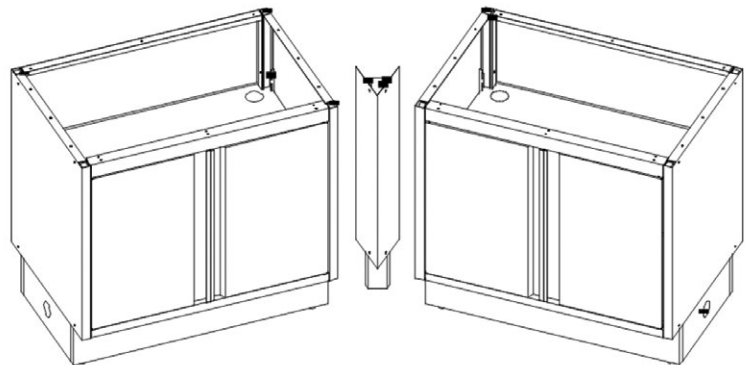

90 DEGREE FILLER PANEL FEATURES:

- Designed to attach two units for an inside 90 degree corner
- Fills base and cabinet area

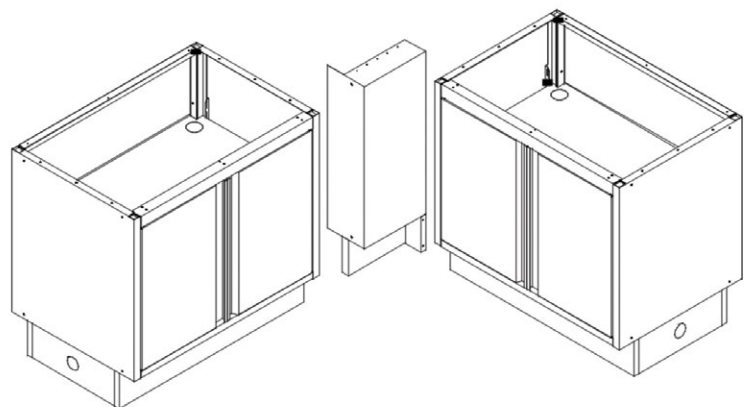



S2G Metal Cabinets

BASE PANEL FILLER FEATURES:

- To fill base opening between cabinet base and wall
- To be used in place of end filler for cabinets without chase

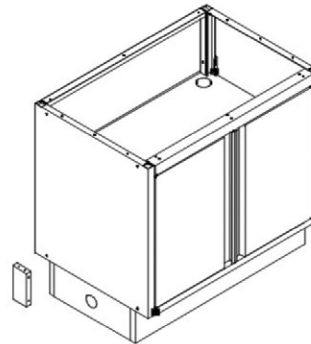

END FILLER PANEL FEATURES:

- Designed to finish off the opening of a standard 5 1/2" chase
- Finishes base and cabinet area at the end of a run

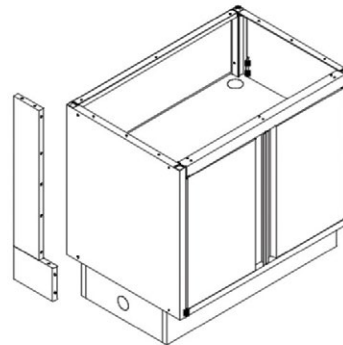

ADJUSTABLE FILLER PANEL FEATURES:

- Designed to complete a cabinet run unequal to length of standard cabinet bodies. *Easily cut to size in field; adjustable from 2" to 12" in length
- Unique design provides finished edges after cutting to size

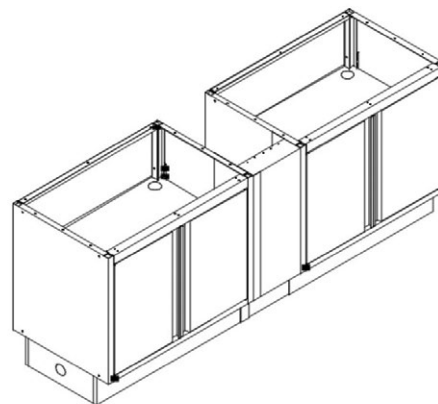



S2G Metal Cabinets

CUP DISPENSERS:

- One-size-fits-all adjustable cup dispenser utilizes a three clip design for a variety of paper, plastic and foam cups. The fingers can be adjusted to fit 8 oz. to 44 oz. size cups without having to be removed from the cabinet. Available in 18" and 23" lengths.

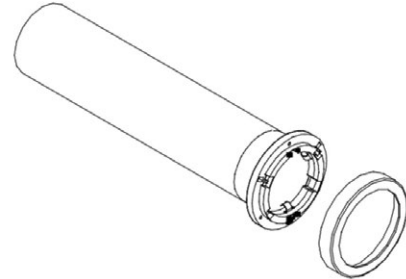

ADJUSTABLE INTERIOR SHELF:

- Requires two brackets

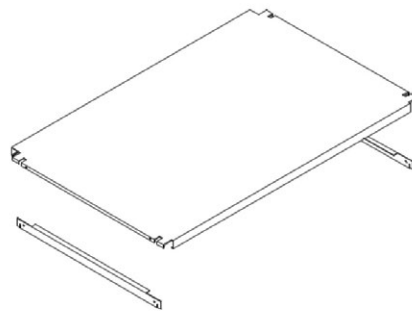

STAINLESS STEEL & POWDER COATED LEGS:

- To be used in place of standard base when desired
- Height is adjustable from 5.5" to 9.5"
- Castors are also an available option

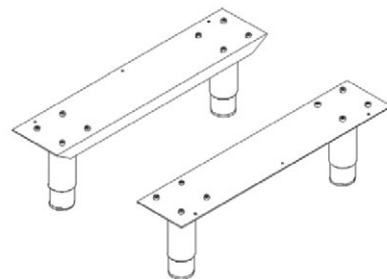

FULL BACK PANEL:

- Back panel without chase opening
- Available for all cabinet sizes
- Supplied standard on trash unit

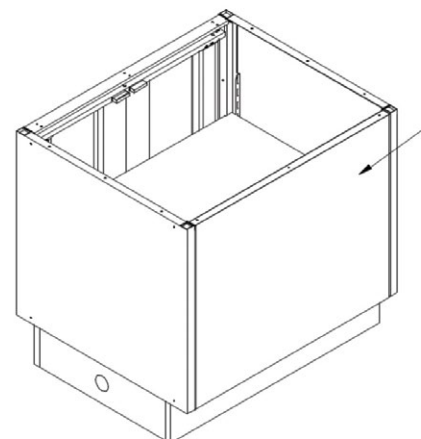



S2G Metal Cabinets

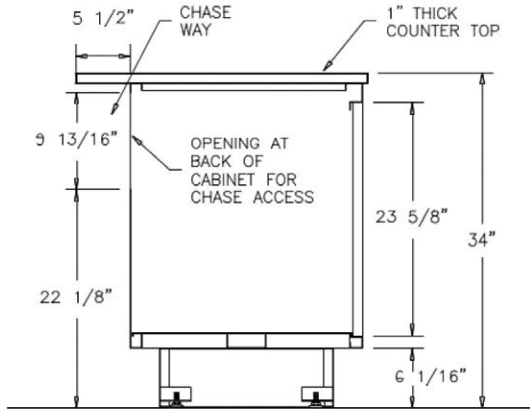

STANDARD PREP UNIT

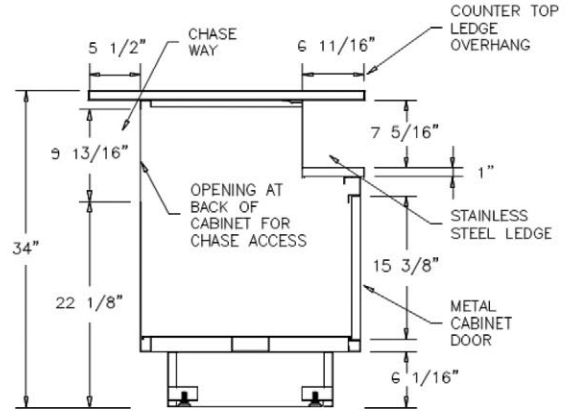

BEVERAGE UNIT

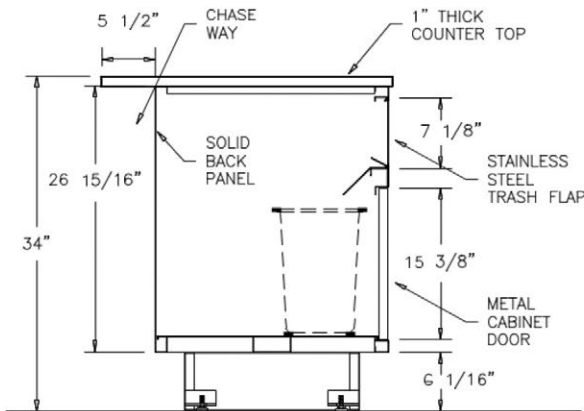

TRASH UNIT

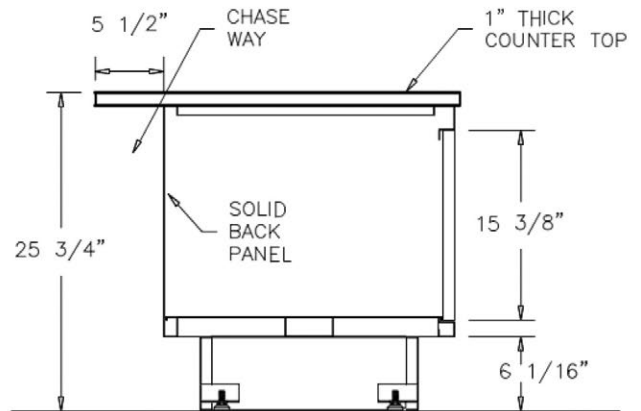

LOW PREP UNIT

ACTUAL CABINET LENGTHS

NOMINAL LENGTH	ACTUAL LENGTH
12"	11-13/16"
18"	17 -3/4"
24"	23 -5/8"
30"	29 -1/2"
36"	35 -7/16"
48"	47 -1/4"



S2G Metal Cabinets





Madix Gondola Systems

Madix Gondola Shelving is an industry standard that is compatible with many domestic shelving systems, giving you the option of buying Madix shelves on a quick ship basis for your existing domestic shelving systems. It also allows you to order new Madix gondolas from SHOPCO while using existing shelves from your current inventory.

Madix store fixtures are manufactured in a highly automated facility with the most modern technology to create store fixtures that are as cost efficient as they are functional. Uprights are engineered of heavy gauge steel with a one inch slot pattern for adjustability and conformity to many other manufacturer's shelves, as well as vendor racks.

The five inch high foot is designed for ease of installation and structural integrity with levelers for use on all types of floors. The high density hardboard back panels fit flush with the front of the upright and are available in two colors (in stock in Black and Sahara). Madix Gondolas and wall units are stocked in 3-ft and 4-ft lengths, 48-in, 54-in, 60-in, 72-in, 84-in, and 96-in heights, with base decks from 12-in, 14-in, 16-in, 18-in and 22-in depths. Installation and assembly of Madix Gondolas or Wall Shelving in your store is easy.

Black and Sahara (beige) in inventory.

SHOPCO was chosen by Madix to be one of only a select few to be a master distributors of Madix products nationally!





Madix Gondola Systems

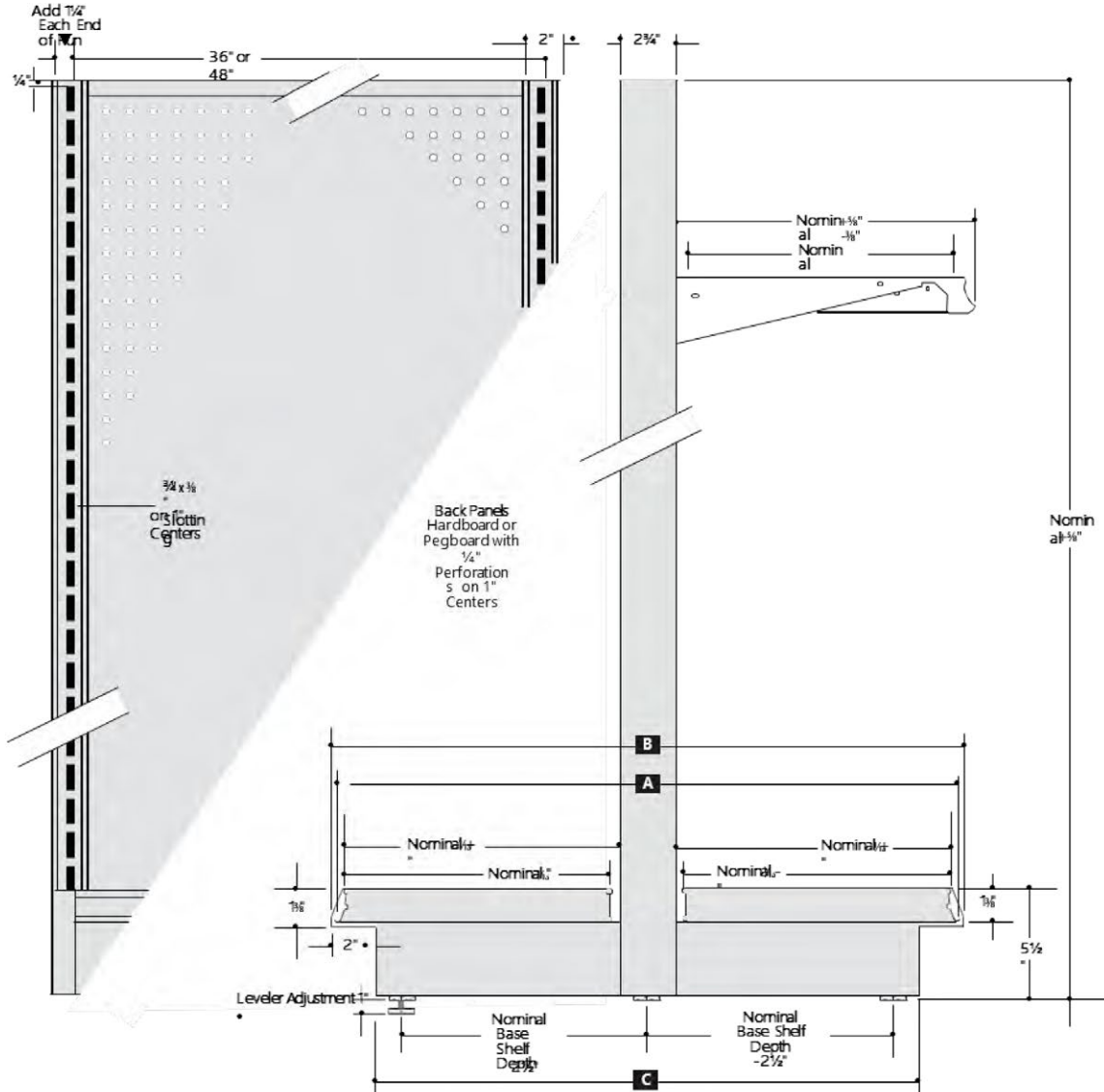

- Nominal Upright Heights 36" (914 mm) thru 96" (2438 mm) in 6" (152 mm) increments
- Nominal Base Shelf Depths 12" (305 mm) thru 30" (762 mm) in 2" (51 mm) increments
- Nominal Upper Shelf Depths 8" (203 mm) thru 30" (762 mm) in 2" (51 mm) increments

Nominal Base Shelf Depth	plus 3" plus	Nominal Base Shelf Depth	equals	Nominal Base Width
Bottom of Tag Mold to Bottom of Tag Mold	A	equals	Nominal Base Width	minus 1/4"
Front of Base End Cover to Front of Base End Cover	B	equals	Nominal Base Width	plus 7/8"
	C	equals		minus 31/4"



Madix Gondola Systems

GONDOLA PEGBOARD - STARTER

Length	Height	Depth
3'	48"	12", 14", 16", 18" and 22"
4'	48"	12", 14", 16", 18" and 22"
3'	54"	12", 14", 16", 18" and 22"
4'	54"	12", 14", 16", 18" and 22"
3'	60"	12", 14", 16", 18" and 22"
4'	60"	12", 14", 16", 18" and 22"
3'	72"	12", 14", 16", 18" and 22"
4'	72"	12", 14", 16", 18" and 22"

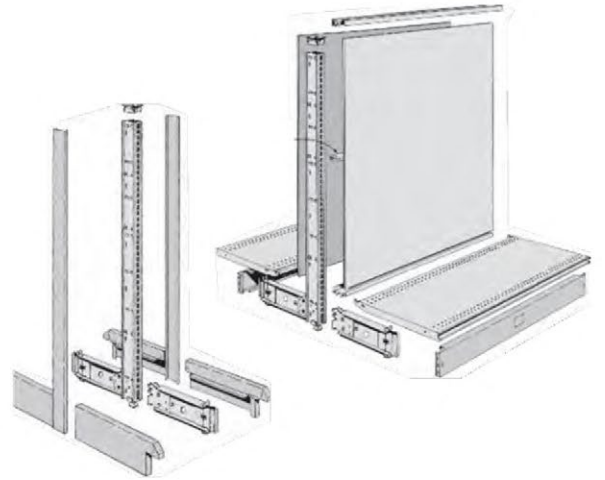

* SIDE BASE PANELS - ORDERED SEPARATELY

GONDOLA - SIDE BASE PANELS FOR STARTER

Depth	Height
10"	6"
12"	6"
14"	6"
16"	6"
18"	6"
22"	6"
3'	72"
4'	72"



GONDOLA PEGBOARD - ADD-ON

Length	Height	Depth
3'	48"	12", 14", 16", 18" and 22"
4'	48"	12", 14", 16", 18" and 22"
3'	54"	12", 14", 16", 18" and 22"
4'	54"	12", 14", 16", 18" and 22"
3'	60"	12", 14", 16", 18" and 22"
4'	60"	12", 14", 16", 18" and 22"
3'	72"	12", 14", 16", 18" and 22"
4'	72"	12", 14", 16", 18" and 22"





Madix Gondola Systems

END CAP - PEGBOARD - STARTER

Length	Height	Depth
3'	48"	12", 14" 16" 18" and 22"
3'	54"	12", 14" 16" 18" and 22"
3'	60"	12", 14" 16" 18" and 22"
3'	72"	12", 14" 16" 18" and 22"

* BLACK OR SAHARA (BEIGE)

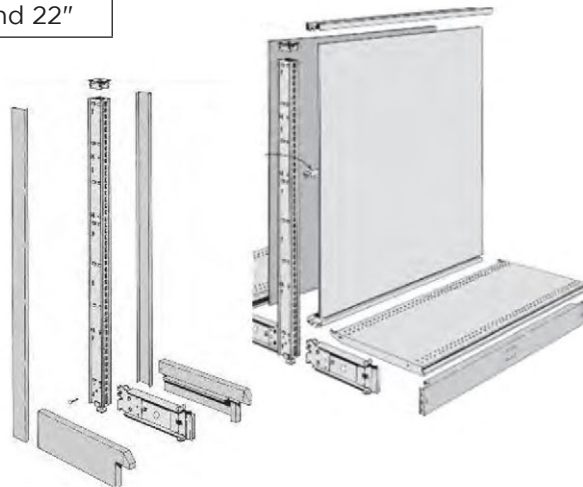

END FRAME - PEGBOARD - STARTER

Length	Height	Depth
3'	54"	n/a
3'	72"	n/a

* BLACK OR SAHARA (BEIGE)

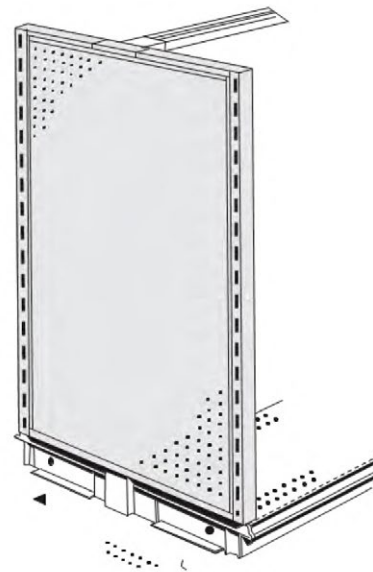



Madix Gondola Systems

WALL UNIT - PEGBOARD - STARTER PEGBOARD FRONT - OPEN BACK

Length	Height	Depth
3'	48"	12", 14", 16", 18" and 22"
4'	48"	12", 14", 16", 18" and 22"
3'	54"	12", 14", 16", 18" and 22"
4'	54"	12", 14", 16", 18" and 22"
3'	60"	12", 14", 16", 18" and 22"
4'	60"	12", 14", 16", 18" and 22"
3'	72"	12", 14", 16", 18" and 22"
4'	72"	12", 14", 16", 18" and 22"
3'	84"	16" 18" and 22"
4'	84"	16" 18" and 22"
3'	96"	16" 18" and 22"
4'	96"	16" 18" and 22"

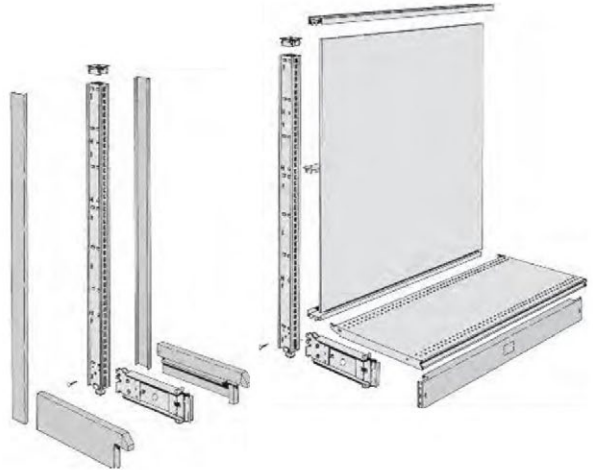

* BLACK OR SAHARA (BEIGE)

WALL UNIT - PEGBOARD - ADD-ON PEGBOARD FRONT - OPEN BACK

Length	Height	Depth
3'	48"	12", 14", 16", 18" and 22"
4'	48"	12", 14", 16", 18" and 22"
3'	54"	12", 14", 16", 18" and 22"
4'	54"	12", 14", 16", 18" and 22"
3'	60"	12", 14", 16", 18" and 22"
4'	60"	12", 14", 16", 18" and 22"
3'	72"	12", 14", 16", 18" and 22"
4'	72"	12", 14", 16", 18" and 22"
3'	84"	16" 18" and 22"
4'	84"	16" 18" and 22"
3'	96"	16" 18" and 22"
4'	96"	16" 18" and 22"



* BLACK OR SAHARA (BEIGE)



Madix Gondola Systems

WIRE SHELVES WITH BRACKETS

Length	Depth
3'	10", 12", 14" and 16"
4'	12", 14" and 16"

* BLACK ONLY

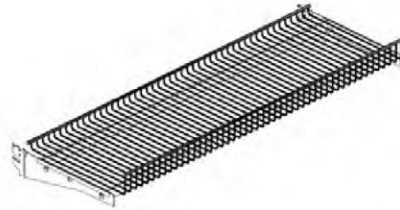

PEG HOOK - FLIP SCAN

Length	Color
4"	Black or Galvanized
6"	Black or Galvanized
8"	Black or Galvanized
11"	Black or Galvanized

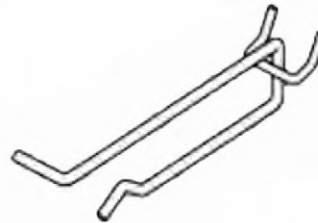

2-TIER PASTRY SHELF

Length
3'

* BLACK OR SAHARA (BEIGE)

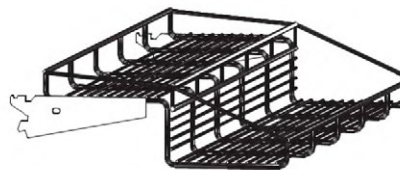



Madix Gondola Systems

SOLID SHELVES WITH BRACKETS

Length	Depth
3'	8", 10", 12", 14" 16" 18", 20" and 22"
4'	8", 10", 12", 14" 16" 18", 20" and 22"

* BLACK OR SAHARA (BEIGE)



WIRE FRONT FENCE

Length	Depth
3'	4"
4'	4"

* BLACK OR SAHARA (BEIGE)

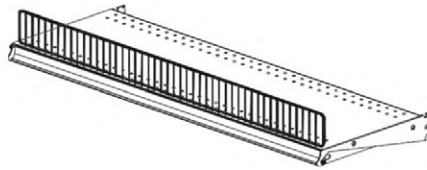

STYRENE FRONT FENCE

Length	Depth
3'	3"
4'	3"

* CLEAR

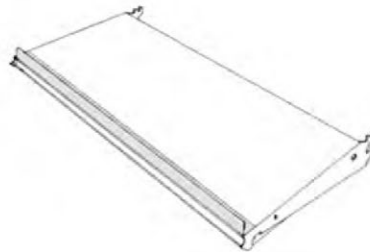

SHELF RETAINER FOR SOLID SHELF

Length	Depth
3'	1"
4'	1"

* BLACK OR SAHARA (BEIGE)

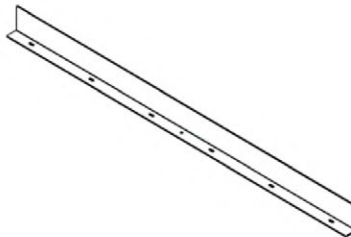



Madix Gondola Systems

POWER WING

- Attaches to end cap units
- 14.5”L x 4.5”D x 36”H
- Standard stock colors are Black and Sahara (beige)
- Includes mounting clips and hardware

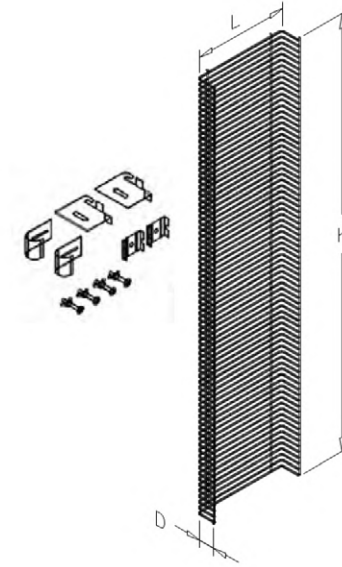

POWER WING MERCHANDISER (ATTACHES TO END CAP UNIT)

Length	Depth	Height
14.5”	4.5”	36”

POWER WING SHELF

Length	Depth	Height
13”	4”	5”

* STANDARD STOCK COLORS ARE BLACK AND SAHARA (BEIGE)

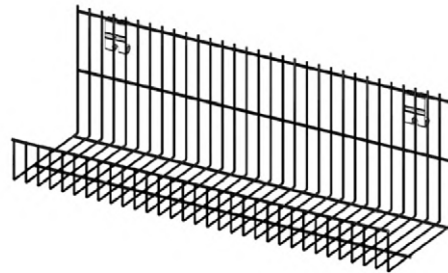

POWER WING HOOK

- Length 4”
- Standard stock color is galvanized
- Includes label holder

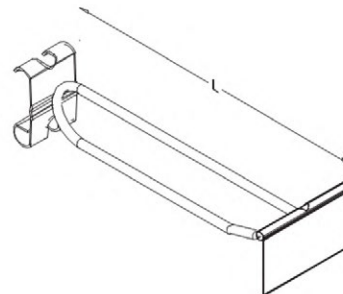



Madix Gondola Systems





Madix Gondola Systems





Specialty Fixtures

SHOPCO provides a vast assortment of Specialty Fixtures to meet your everyday merchandising needs. Can't find what you're looking for? If not, please contact your SHOPCO Representative to discuss your ideas and let us design a product to fit your specific needs!



CUSTOM WASTE RECEPTACLES



BEER TUBS





Tobacco Fixtures

SHOPCO USA: Is now a distributor for Imageworks fixtures

Classic version:

- Affordable
- Built to your needs to match your budget. Addresses all tobacco lines and can be fully customized
- Flexible
- High & low-profile options available. 55 - 99.5"
- Available in 2', 3', or 4' widths.
- Quality
- Durable metal frame construction; simple installation
- Illuminated & Digital Headers
- LED Shelf Lighting
- Locking Storage Drawers

Impact Version:

- Ultimate Versatility
- One foot shelving featuring vertical adjustability in 1/2" increments
- No Gaps - continuous product presentation
- Adjustable Profiles
- Available in low, condensed, and high profiles
- Adjustable in 3" increments (55" - 88")
- Simplify Resets
- Easily reconfigure product and signage, not the frame
- Illuminated & Digital Headers
- LED Shelf Lighting
- Locking Storage Drawers
- Locking Security Doors





Design Services

With SHOPCO's AutoCAD design service, our design department can create an exciting new Metal Cabinet layout that is customized to fit your store's specific requirements.

Our design department not only creates entire new store layouts, but can also retrofit your existing store in order to provide a functional design with a contemporary upscale look and feel. Take advantage of SHOPCO's CAD Design Service today!

Call to start creating your customized merchandising solutions with one of our design experts. Send your electronic architectural drawing to designcenter@shopcousa.com.

CAD

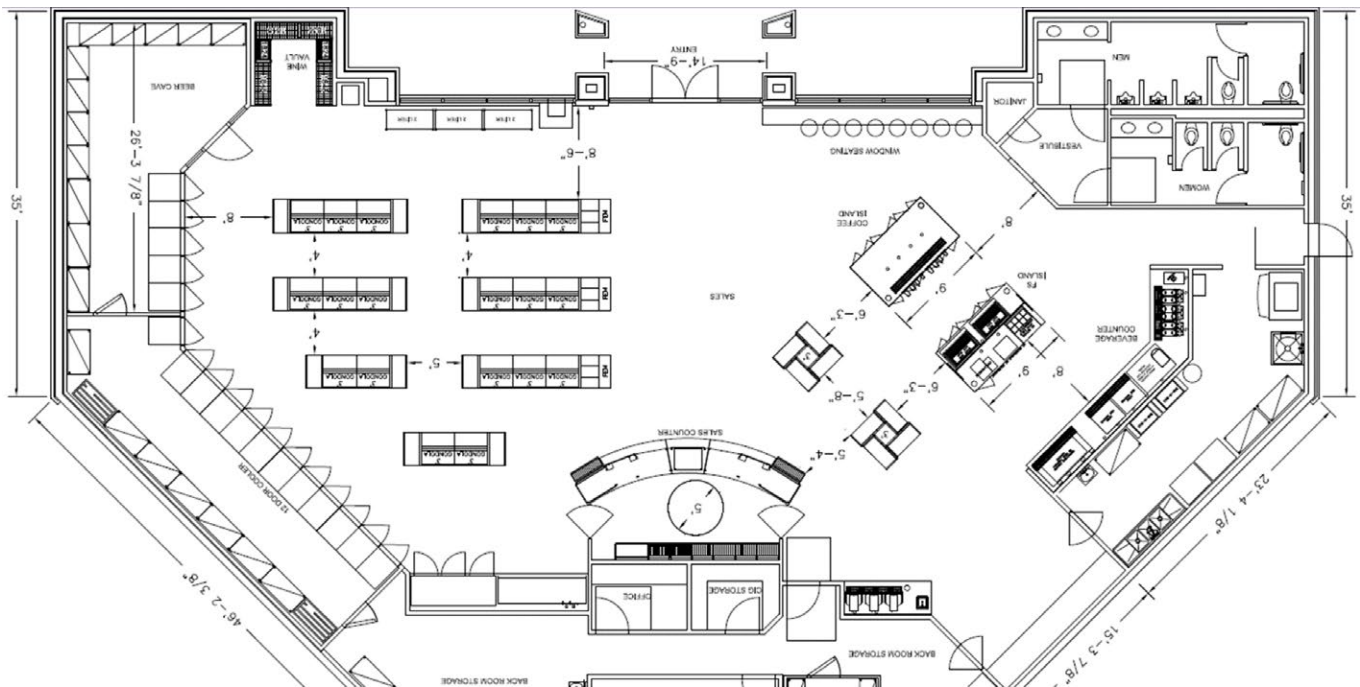



SHOPCO USA

SHOPCO USA

7171 W. Sam Houston Parkway North
Houston, TX 77040

Website/ www.shopcousa.com

Phone 713.934.2900 | Fax 713.934.2929